



# **AIRLESS PAINT SPRAYER SERVICE/OPERATION MANUAL**



**AIRLESSCO  
LP460 - LP540 - LP690**

**ALLPRO  
510E - 710E - 810E**

# TABLE OF CONTENTS

## Introduction

LP Series Specifications.....	1
Safety Warnings.....	2

## Getting Started

Flushing.....	5
How to Flush.....	5
Setting Up.....	7
Starting Up.....	8
Pressure Relief Procedure.....	10
Daily Maintenance.....	10

## Repairs/Maintenance Instructions

Spray Gun Operation.....	11
Spray Gun Troubleshooting.....	12
Spray Tip Selection.....	13
Electric Motor Maintenance.....	14
Field Troubleshooting.....	15
Servicing the Fluid Pump.....	16
Servicing Piston Rod, Outlet Valve.....	18
Servicing Suction Assembly.....	18
Packing Replacement.....	19
Electrical Board Calibration.....	25
Electrical Troubleshooting - 5/6 Series.....	27
Replacement of Electrical Components.....	29

## Product Diagrams & Parts Lists

Manifold Filter Parts List.....	14
Gear & Pump Assembly.....	17
Upper & Lower Seats.....	18
Fluid Pump.....	20
Carry Frame Machine Parts List.....	21
Lo-Boy Machine Parts List.....	22
Hi-Boy Machine Parts List.....	23
Suction Assemblies.....	24
Electrical System Drawing - 5/6 Series.....	28

## Quick Reference Guide

Single Sheet of Instructions for Operation & Cleaning of an Airless Paint Sprayer.....	30
---	----

**Manufactured by: AIRLESSCO BY DUROTECH CO.**

Ship to: 5397 N Commerce Ave.,  
Moorpark, CA 93021 Tel: 800-223-8213 Fax: 805-523-1063  
**www.airlessco.com email: techsupport@airlessco.com**

SUBJECT TO CHANGE WITHOUT NOTICE.  
Copyright © 2006, All rights reserved.



# INTRODUCTION



Your new Airlessco or ALLPRO airless paint sprayer is designed to meet the demands of the professional painting contractor as well as the homeowner. The famous Airlessco slow-stroking stainless steel piston pump delivers extra long life for the piston, packings, valve seats and balls. The patented Triple-Life packing system is externally adjustable, extending packing life and reducing repacking costs. Its large high-torque electric motor runs slower reducing heat. The motor is fan cooled and totally enclosed to reduce brush wear and to prevent the ignition of paint fumes in the motor.

	LP460/510E	LP540/610E	LP690/810E
Max. Pressure	3000 psi	3000 psi	3000 psi
Output (FreeFlow)	0.5 gpm	0.7 gpm	0.8 gpm
Output (At Pressure)	0.46 gpm	0.54 gpm	0.6 gpm
Tip Size	1 gun up to 0.021	1 gun up to 0.023	1 gun up to 0.026
Motor- Output	DC TEFC .6 hp	DC TEFC .8 hp	DC. TEFC. .8 hp
Weight	38 lbs	41 lbs.	65 lbs.



CARRY FRAME MODEL



LO-BOY FRAME



HI-BOY FRAME

## WARNING

**HANDLE THIS UNIT AS YOU WOULD A LOADED FIREARM!**  
**High pressure spray can cause extremely serious injury.**  
**OBSERVE ALL WARNINGS!**

Before operating this unit, read and follow all safety warnings and instructions related to the usage of this equipment on pages 2, 3 & 4. **READ, LEARN, and FOLLOW** the Pressure Relief Procedure on Page 10 of this manual.

All Service Procedures to be performed by an Authorized Airlessco Service Center ONLY.

**NO MODIFICATIONS** or alterations of any AIRLESSCO Equipment or part is allowed.

### MANUAL NOTATIONS

**WARNING** - Alerts user to avoid or correct conditions that could cause bodily injury.

**CAUTION** - Alerts user to avoid or correct conditions that could cause damage to or destruction of equipment.

**IMPORTANT** - Alerts users to steps or procedures that are essential to proper equipment repair and maintenance.

**NOTE** - Identifies essential procedures or extra information.

# SAFETY WARNINGS

**HIGH PRESSURE SPRAY CAN CAUSE EXTREMELY SERIOUS INJURY.**  
**Handle as you would a loaded firearm.**  
**Follow the PRESSURE RELIEF PROCEDURE.**

## DO NOT USE HALOGENATED SOLVENTS IN THIS SYSTEM.

The prime valve, and most airless guns have aluminum parts and may explode. Cleaning agents, coatings, paints or adhesives may contain halogenated hydrocarbon solvents. **DON'T TAKE CHANCES!** Consult your material suppliers to be sure. Some of the most common of these solvents are: Carbontetrachloride, Chlorobenzene, Dichloroethane, Dichloroethyl Ether, Ethylbromide, Ethylchloride, Tetrachloethane. Alternate valves and guns are available if you need to use these solvents.

## **MEDICAL ALERT - Airless Spray Wounds**

If any fluid appears to penetrate your skin, get **EMERGENCY MEDICAL CARE AT ONCE.**  
**DO NOT TREAT AS A SIMPLE CUT.**  
Tell the doctor exactly what fluid was injected.

**NOTE TO PHYSICIAN:** Injection in the skin is a traumatic injury. **It is important to treat the injury surgically as soon as possible. DO NOT DELAY treatment to research toxicity.** Toxicity is a concern with some exotic coatings injected directly into the blood stream. Consultation with a plastic surgeon or reconstructive hand surgeon may be advisable.

## INJECTION HAZARD

- Fluids under high pressure from spray or leaks can penetrate the skin and cause extremely serious injury, including the need for amputation.
- **NEVER** point the spray gun at anyone or any part of the body.
- **NEVER** put your hand or fingers over the spray tip. Do not use a rag or any other materials over your fingers. Paint will penetrate through these materials & into the hand.
- **NEVER** try to stop or deflect leaks with your hand or body.
- **ALWAYS** have the tip guard in place when spraying.
- **ALWAYS** lock the gun trigger when you stop spraying.
- **ALWAYS** remove tip from the gun to clean it.
- **NEVER** try to "blow back" paint, this is not an air spray sprayer.
- **ALWAYS** follow the **PRESSURE RELIEF PROCEDURE** before cleaning or removing the spray tip or servicing any system equipment.
- Be sure the equipment safety devices are operating properly before each use.
- Tighten all of the fluid connections before each use.

## MEDICAL TREATMENT

- If any fluid appears to penetrate your skin, get **EMERGENCY CARE AT ONCE! DON'T TREAT AS A SIMPLE CUT.**
- Go to an emergency room immediately.
- Tell the doctor you suspect an injection injury.
- Tell him what kind of material you were spraying with and have him read **NOTE TO PHYSICIAN** above.

## GENERAL PRECAUTIONS

- **NEVER** alter equipment in any manner.
- **NEVER** smoke while in spraying area.
- **NEVER** spray highly flammable materials.
- **NEVER** use around children.
- **NEVER** allow another person to use sprayer unless he is thoroughly instructed on its safe use and given this operators manual to read.
- **ALWAYS** wear a spray mask, gloves and protective eye wear while spraying.
- **ALWAYS** ensure fire extinguishing equipment is readily available and properly maintained.

**NEVER LEAVE SPRAYER UNATTENDED WITH PRESSURE IN THE SYSTEM.**

**FOLLOW PRESSURE RELIEF PROCEDURES.**

**NOTE: United States Government safety standards have been adopted under the Occupational Safety & Health Act. These standards, particularly the General Standards, Part 1910 & Construction Standards, Part 1926 should be consulted.**

# SAFETY WARNINGS

## ALWAYS INSPECT SPRAYING AREA

- Keep the spraying area free from obstructions.
- Make sure the spraying area has good ventilation to safely remove vapors and mists.
- **NEVER** keep flammable material in spraying area.
- **NEVER** spray in vicinity of open flame or other sources of ignition.
- The spraying area must be at least 20 ft. away from spray unit.

## SPRAY GUN SAFETY

- **ALWAYS** set gun safety lock in the "LOCKED" position when not in use & before servicing or cleaning.
- **NEVER** remove or modify any part of the gun.
- **ALWAYS** REMOVE THE SPRAY TIP when cleaning. Flush unit at the **LOWEST POSSIBLE PRESSURE**.
- **ALWAYS** check operation of all gun safety devices before each use.
- Be very careful when removing the spray tip or hose from the gun. A plugged line will contain fluid under pressure. If the tip or line is plugged, follow the **PRESSURE RELIEF PROCEDURE**.

## TIP GUARD

- **ALWAYS** have the tip guard in place on the spray gun while spraying. The tip guard alerts you to the injection hazard and helps prevent accidentally placing your fingers or any part of your body close to the spray tip.

## SPRAY TIP SAFETY

- Use extreme caution when cleaning or changing spray tips. If the spray tip clogs while spraying, engage the gun safety latch immediately. **ALWAYS** follow the **PRESSURE RELIEF PROCEDURE** and then remove the spray tip to clean it.
- **NEVER** wipe off build up around the spray tip.

## TOXIC FLUID HAZARD

- **ALWAYS** remove tip guard & tip to clean **AFTER** pump is turned off and the pressure is relieved by following the **PRESSURE RELIEF PROCEDURE**.
- Hazardous fluid or toxic fumes can cause serious injury or death if splashed in eyes or on skin, inhaled or swallowed. Know the hazards of the fluid you are using. Store & dispose of hazardous fluid according to manufacturer, local, state & national guidelines.
- **ALWAYS** wear protective eyewear, gloves, clothing and respirator as recommended by fluid manufacturer.

## HOSES

- Tighten all of the fluid connections securely before each use. High pressure fluid can dislodge a loose coupling or allow high pressure spray to be emitted from the coupling and result in an injection injury or serious bodily injury.
- Only use hoses with a spring guard. The spring guard helps protect the hose from kinks or other damage which could result in hose rupture and cause an injection injury.
- **NEVER** use a damaged hose, which can result in hose failure or rupture and cause an injection injury or other serious bodily injury or property damage. Before each use, check entire hose for cuts, leaks, abrasions, bulging of the cover, or damage or movement of couplings. If any of these conditions exist, replace the hose immediately.
- **NEVER** use tape or any device to try to mend the hose as it cannot contain the high pressure fluid. **NEVER ATTEMPT TO RECOUPLE THE HOSE**. A high pressure hose is not recoupleable.

## GROUNDING

- Ground the sprayer & other components in the system to reduce the risk of static sparking, fire or explosion which can result in serious bodily injury and property damage. For detailed instructions on how to ground, check your local electrical code.
- **ALWAYS** ensure switch is in OFF position before plugging unit in.

## Always Ground All of These Components:

1. **Sprayer:** plug the power supply cord, or extension cord, each equipped with an undamaged three-prong plug, into a properly grounded outlet. **DO NOT USE AN ADAPTER**. Use only a 3 wire extension cord that has a 3 blade grounding plug, and a 3 slot receptacle that will accept the plug on the product. Make sure your extension cord is in good condition. When using an extension cord, be sure to use one heavy enough to carry the current your product will draw. (**Note:** The table on the top of the next page shows the correct size to use depending on cord length and name plate ampere rating. If in doubt, use the next heavier gauge. The smaller the gauge number, the heavier the cord.)
  2. **Fluid hose:** use only grounded hoses.
  3. **Spray gun or dispensing valve:** grounding is obtained through connection to a properly grounded fluid hose and pump.
  4. **Object being sprayed:** according to your local code.
  5. **All solvent pails** used when flushing.
- Once each week, check electrical resistance of hose (when using multiple hose assemblies, check overall resistance.) Overall (end to end) resistance of unpressurized hose must not exceed 29 megohms (max.) for any coupled length or combination of hose lengths. If hose exceeds these limits, replace it immediately.
  - Never exceed 500 ft. (150 m) overall combined cord length to assure electrical continuity.

# SAFETY WARNINGS

## UL RECOMMENDATION FOR MINIMUM GAUGE EXTENSION CORD

AMPERAGE RATING RANGE	VOLTAGE	LENGTH OF CORD IN FEET								
		25	50	100	150	200	250	300	400	500
5 - 6	120	18	16	12	12	10	10	8	8	6
6 - 8	120	18	16	12	10	10	8	6	6	6
8 - 10	120	18	14	12	10	8	8	6	6	4
10 - 12	120	16	14	10	8	8	6	6	4	4

### Always Follow Recommended Pressure and Operating Instructions

#### KEEP CLEAR OF MOVING PARTS

Keep clear of moving parts when starting or operating the sprayer. Do not put your fingers into any openings to avoid amputation by moving parts or burns on hot parts. Precaution is the best insurance against an accident. When starting the motor, maintain a safe distance from moving parts of the equipment. Before adjusting or servicing any mechanical part of the sprayer, follow the PRESSURE RELIEF PROCEDURE.

#### AVOID COMPONENT RUPTURE

- This sprayer operates at 3000 psi (205 bar). Always be sure that all components and accessories have a maximum working pressure of at least 3000 psi to avoid rupture which can result in serious bodily injury including injection and property damage.
- **NEVER** leave a pressurized sprayer unattended to avoid accidental operation of it, which could result in serious bodily injury.
- **ALWAYS** follow the PRESSURE RELIEF PROCEDURE whenever you stop spraying and before adjusting, removing or repairing any part of the sprayer.
- **NEVER** alter or modify any part of the equipment to avoid possible component rupture which could result in serious bodily injury and property damage.
- **NEVER** use weak, damaged, or non-conductive paint hose. Do not allow kinking or crushing of hoses or allow it to vibrate against rough, sharp or hot surfaces. Before each use, check your hoses for damage and wear and ensure all of the fluid connections are secure.
- **ALWAYS** replace any damaged hose. **NEVER** use tape or any device to mend the hose.
- **NEVER** attempt to stop any leakage in the line or fittings with your hand or any part of the body. Turn off the unit and release pressure by following PRESSURE RELIEF PROCEDURE.

#### WHEN SPRAYING & CLEANING WITH FLAMMABLE PAINTS AND THINNERS

1. When spraying with flammable liquids, the unit must be located a minimum of 25 feet away from the spraying area in a well ventilated area. Ventilation must be sufficient enough to prevent the accumulation of vapors.
2. To eliminate electrostatic discharge, ground the spray unit, paint bucket & spraying object. See GROUNDING. Use only high pressure airless hoses approved for 3000 psi which is conductive.
3. Remove the spray tip before flushing. Hold the metal part of the gun firmly to the side of a metal pail & use the lowest possible fluid pressure during flushing.
4. Never use high pressure in the cleaning process. **USE MINIMUM PRESSURE.**
5. Do not smoke in spraying/cleaning area.

- **ALWAYS** use approved high pressure fittings and replacement parts.
- **ALWAYS** ensure fire extinguishing equipment is readily available and properly maintained.

#### PREVENT STATIC SPARKING FIRE/EXPLOSIONS

- **ALWAYS** be sure all of the equipment & objects being sprayed are properly grounded. Always ground sprayer, paint bucket and object being sprayed. See the grounding section of this manual for grounding information.
- Vapors created when spraying can be ignited by sparks. To reduce the risk of fire, always locate the sprayer at least 20 feet (6 m.) away from spray area. Do not plug in or unplug any electrical cords in the spray area. Doing so can cause sparks which can ignite any vapors still in the air. Follow the coating & solvent manufacturers safety warnings and precautions.
- Use only conductive fluid hoses for airless applications. Be sure the gun is grounded through the hose connections. Check ground continuity in hose & equipment. Overall (end to end) resistance of unpressurized hose must not exceed 29 megohms for any coupled length or combination of hose length. Use only high pressure airless hoses with static wire approved for 3000 psi.

#### FLUSHING

- Reduce the risk of injection injury, static sparking or splashing by following the specific cleaning process.
- **ALWAYS** follow the PRESSURE RELIEF PROCEDURE.
- **ALWAYS** remove the spray tip before flushing. Hold the metal part of the gun firmly to the side of a metal pail & use the lowest possible fluid pressure during flushing.
- **NEVER** use cleaning solvents with flash points below 140 degrees F. Some of these are: acetone, benzene, ether, gasoline, naphtha. Consult your supplier to be sure.
- **NEVER** SMOKE in the spraying/cleaning area.

# FLUSHING

## **1. New Sprayer**

Your sprayer was factory tested in an oil solution which was left in the pump. **Before using oil-base paint**, flush with mineral spirits only. **Before using water-base paint** flush with mineral spirits, followed by soapy water, then a clean water flush.

## **2. Changing Colors**

Flush with a compatible solvent such as mineral spirits or water.

## **3. Changing from water-base to oil-base paint.**

Flush with soapy water, then mineral spirits.

## **4. Changing from oil-base to water-base paint.**

Flush with mineral spirits, followed by soapy water, then a clean water flush.

## **5. Storage**

**Always relieve pressure (See pressure relief procedure on page 10) prior to storage or when machine is unattended.**

**Oil-base Paint:** Flush with mineral spirits. Ensure that there is no pressure in the unit, then close the prime/pressure relief valve.

**Water-base Paint:** Flush with water, then mineral spirits. For longer term storage use a 50/50 mixture of mineral spirits and motor oil. Always ensure that there is no pressure in the unit, and close the prime/pressure relief valve for storage.

## **6. Start-up after storage**

**Before using water-base paint**, flush with soapy water and then a clean water flush.

**When using oil-base paint**, flush out the mineral spirits with the material to be sprayed.

### **WARNING**

**NEVER leave pump unattended while under pressure!**

# HOW TO FLUSH

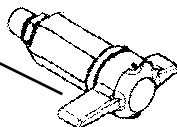
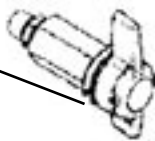
**FIGURE 1**

### **Prime/Pressure Relief Valve (Prime/PR Valve)**

Used to relieve pressure from gun, hose & tip and to prime the unit when in OPEN position.

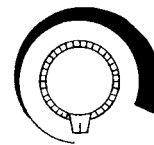
(It is in open position when there is a wider gap between valve handle and cam body).

When valve is in the CLOSED position, there is only a very slight gap between handle & body. When closed the system is pressurized.



**Handle as a Loaded Firearm!**

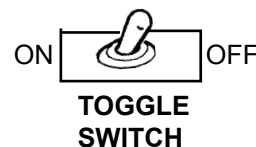
**FIGURE 2**



### **PRESSURE CONTROL KNOB. (FIG. 2)**

Used to adjust pressure. Turn clockwise (CW) to increase pressure and counterclockwise (CCW) to decrease pressure.

**FIGURE 3**



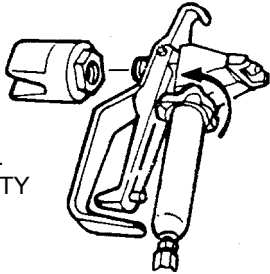
Continued on next page.....

# HOW TO FLUSH (continued)

1. Be sure the gun safety latch is engaged and there is no spray tip in the gun. Refer to page 14 on how to lock the safety latch and the gun's safety features.

**FIGURE 4**

REMOVE SPRAY TIP.  
ENGAGE GUN SAFETY  
LATCH.



2. Pour enough clean, compatible solvent into a large, empty metal pail to fill the pump and hoses.
3. Place the suction tube into the pail.
4. Turn the Prime/Pressure Relief (PR) Valve to the "OPEN" , priming position. Refer to Figure 1.
5. Point the gun into the metal pail and hold a metal part of the gun firmly against the pail. Refer to Figure 5.

6. Disengage the gun safety latch and squeeze the gun trigger. Turn the ON-OFF Toggle Switch to the "ON" position (Figure 3) and turn Pressure Control Knob (Figure 2) clockwise to increase pressure just enough to start the pump.
7. Turn the Prime/PR Valve to the PRESSURE "CLOSED" position. This will allow solvent to be flushed through the pump, hoses and gun. Allow the unit to operate until clean solvent comes from the gun.
8. Release the trigger and engage the gun safety latch.
9. Whenever you shut off the sprayer, follow the "PRESSURE RELIEF PROCEDURE".

**WARNING**

*To reduce the risk of static sparking which can cause fire or explosion, always hold a metal part of the gun firmly against the metal pail when flushing. This also reduces splashing.*

**FIGURE 5**

MAINTAIN FIRM  
METAL TO METAL  
CONTACT BETWEEN  
GUN AND CONTAINER



# SETTING UP

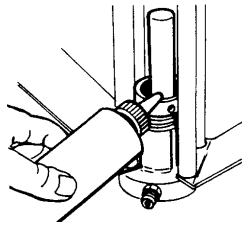
## **1. Connect the hose and gun.**

- a. Remove the plastic cap plug from the outlet tee and screw a conductive or grounded 3000 psi airless spray hose onto fluid outlet.
- b. Connect an airless spray gun to the other end of the hose.
- c. Do not use steel braided airless hose. Use nylon braided airless hose only.

**NOTE:** *Do not use thread sealer on swivel unions as they are made to self-seal. Use thread seal on tapered male threads only.*

## **2. Fill the packing nut/wet cup with 5 drops of Airlessco Throat Seal Oil (TSO).** See (Figure 6).

**FIGURE 6**



## **3. Check the electrical service.**

Be sure the electrical service is 120 VAC, 15 amp minimum, and that the outlet you use is properly grounded.

**NOTE:** *\*For Generator power, a minimum 7000 watt generator with voltage regulation must be used.*

## **4. Grounding**

### **WARNING**

*To reduce the risk of static sparking, fire or explosion which can result in serious bodily injury and property damage, always ground the sprayer and system components and the object being sprayed, as instructed in the safety warning section of this manual.*

## **5. Flush the sprayer**

As per "Flushing Procedure" in this manual.

# STARTING UP

## 1. Learn the functions of the controls.

**PRIME/PRESSURE (PR) RELIEF VALVE** is used to prime pump and to relieve pressure from gun, hose and tip.

## 2. Prepare the material

- Prepare the material according to the material manufacturer's recommendations.
- Place the suction tube into the material container.

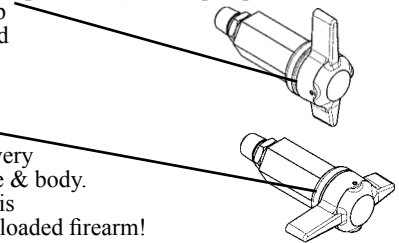
## 3. Starting the sprayer (See Figure 7, 8 & 9)

- Prime/PR Valve must be "OPEN" in the priming position.
- When you have ensured that the gun safety latch is engaged, attach tip and safety guard.
- Turn the ON-OFF Toggle Switch to the "ON" position.
- Turn Pressure Control Knob clockwise to prime the pump.
- After the pump is primed, turn Prime/PR Valve to the "Closed" position.
- Turn Pressure Control Knob to the desired spray pressure. Optional LCD displays pressure.
- Disengage the gun safety latch and you are ready to spray.

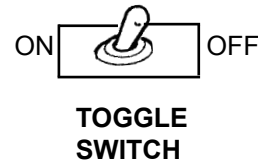
**FIGURE 7**

**Prime/Pressure Relief Valve (Prime/PR Valve)**  
Used to relieve pressure from gun, hose & tip and to prime the unit when in the OPEN position. (It is in open position when there is a wider gap between valve handle and cam body)

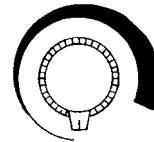
When in the CLOSED position, there is only a very slight gap between handle & body. When closed the system is pressurized. Handle as a loaded firearm!



**FIGURE 8**



**FIGURE 9**



**PRESSURE CONTROL KNOB** is used to adjust pressure. Turn clockwise (CW) to increase pressure and counterclockwise (CCW) to decrease pressure.

# STARTING UP

## 4. Adjusting the pressure

- a. Turn the Pressure Control Knob Clockwise to increase pressure and counterclockwise to decrease pressure.
- b. Always use the lowest pressure necessary to completely atomize the material.

**Note: Operating the sprayer at higher pressure than needed, wastes material, causes early tip wear, and shortens sprayer life.**

- c. If more coverage is needed, use a larger tip rather than increasing the pressure.
- d. Check the spray pattern. The tip size and angle determines the pattern width and flow rate.

### WARNING

**Follow the "Pressure Relief Procedure". To reduce the risk of injection, never hold your hand, body, fingers or hand in a rag in front of the spray tip when cleaning or checking for a cleared tip. Always point the gun toward the ground or into a waste container when checking to see if the tip is cleared or when using a self-cleaning tip.**

### WARNING

**When you spray into the paint bucket, always use the lowest spray pressure and maintain firm metal to metal contact between gun and container.**

### WARNING

**To stop the unit in an emergency, turn the motor off. Then relieve the fluid pressure in the pump and hose as instructed in the Pressure Relief Procedure.**

## Avoiding Tip Clogs

There is an easy way to keep the outside of the tip clean from material build up:

*Every time you stop spraying, for even a minute, lock the gun and submerge it into a small bucket of thinner suitable for the material sprayed.*

*Thinner will dissolve the buildup of paint on the outside of tip, tip guard and gun much more effectively if the paint doesn't have time to dry out completely.*

### WARNING

**Be sure to relieve pressure in the pump after filling with Airlessco Pump Conditioner.**

## 5. When Shutting off the Sprayer

- a. Whenever you stop spraying, even for a short break, follow the "Pressure Relief Procedure".
- b. Clean the tip & gun as recommended in the spray gun instruction manual.
- c. Flush the sprayer at the end of each work day, if the material you are spraying is water-based, or if it could harden in the sprayer overnight. See "Flushing". Use a compatible solvent to flush, then fill the pump and hoses with an oil based solvent such as mineral spirits.
- d. For long term shutdown or storage, refer to the "Flushing" section of this manual.

# PRESSURE RELIEF PROCEDURE

## **IMPORTANT!**

To avoid possible serious body injury, always follow this procedure whenever the sprayer is shut off, when checking it, when installing, changing or cleaning tips, whenever you stop spraying, or when you are instructed to relieve the pressure.

1. Engage the gun safety latch. Refer to the separate instruction manual provided with your gun on its safety features and how to engage safety latch.
2. Turn the unit off & unplug it from the electrical outlet.
3. Disengage the gun safety latch and trigger the gun to relieve residual fluid pressure.

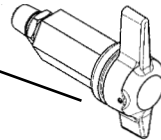
**Hold metal part of the gun in contact with grounded metal pail. USE MINIMUM PRESSURE !**



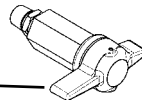
4. Turn Prime/Pressure Relief Valve (PR Valve) to the open (priming) position to relieve residual fluid pressure.

*There will be a wider gap between valve handle and cam body when in open position. In the closed position there is only a very slight gap.*

**NOTE: The valve handle can move both clockwise & counter clockwise and can face different directions.**



5. Re-engage gun safety latch and close Prime/Pressure Relief Valve.



If the **SPRAY TIP OR HOSE IS CLOGGED**, follow Step 1 through 5 above. Expect paint splashing into the bucket while relieving pressure during Step 4.

If you suspect that pressure hasn't been relieved due to damaged Prime/Pressure Relief Valve or other reason, engage the gun safety latch and take your unit to an authorized Airlessco Service Center.

# DAILY MAINTENANCE

1. Keep the displacement pump packing nut/wet cup lubricated with Airlessco TSO (Throat Seal Oil) at all times. The TSO helps protect the rod and the packings.
2. Inspect the packing nut daily. Your pump has a patented Triple Life Packing System. **Packing life will be extended a minimum of three times if the following "Packing Adjustment" procedure is followed:**

*If seepage of paint into the packing nut and/or movement of the piston upward is found (while not spraying), the packing nut should be tightened enough to stop leakage only, but not any tighter. Overtightening will damage the packings and reduce the packing life.*

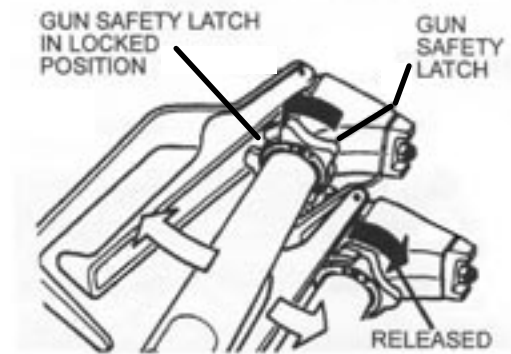
# SPRAY GUN OPERATION

## SPRAY GUN

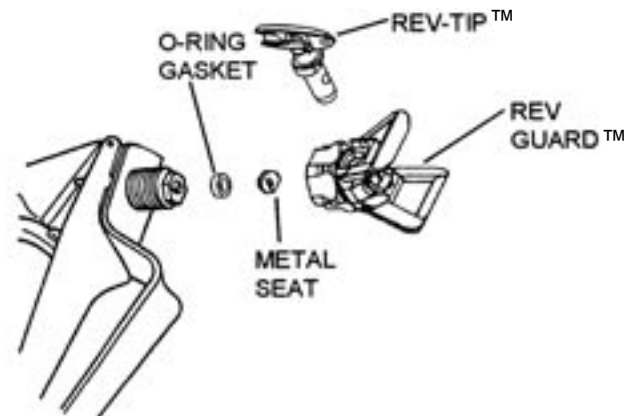
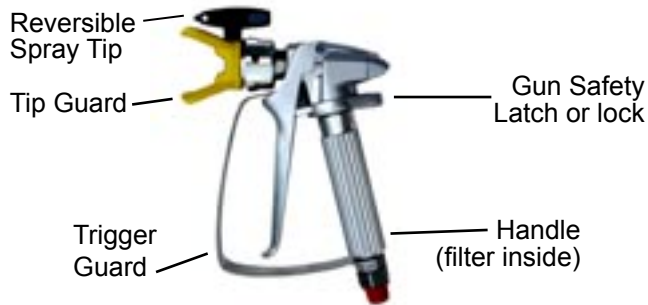
Attach spray gun to airless unit and tighten fittings securely. Set the gun safety latch. (Also may be called gun safety lock, or trigger lock)

\* The gun safety latch should always be set when the gun is not being triggered.

Read all warnings and safety precautions supplied with the spray gun and in product manual.

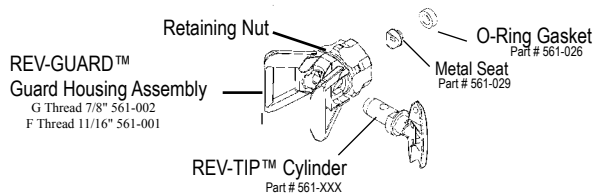


## MAJOR COMPONENTS OF SPRAY GUN AND REVERSIBLE SPRAY TIP



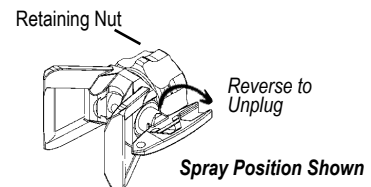
## SPRAY TIP ASSEMBLY

1. Be sure pressure relief procedure is followed before assembling tip and housing to the gun.
2. Lock gun safety latch.
3. Insert REV-TIP™ cylinder into the REV-GUARD™ (guard housing assembly).
4. Guide metal seat into REV-GUARD™ (guard housing assembly) through retaining nut & turn until it seats against the cylinder.
5. Insert O-Ring gasket on metal seat so it fits in the grooves.
6. Finger tighten REV-GUARD™ retaining nut onto the gun.
7. Turn guard in the desired position.
8. Completely tighten the retaining nut.



## TO REMOVE CLOGS FROM SPRAY TIP

1. Lock gun safety latch.
2. Turn REV-TIP™ handle 180 degrees.
3. Disengage trigger lock & trigger gun into pail.
4. If the REV-TIP™ handle appears locked (resists turning), loosen the retaining nut. The handle will now turn easily.
5. Engage gun safety latch & return handle to the spray position.



## CLEANING SPRAY GUN

Immediately after the work is finished, flush the gun out with a solvent. Brush pins with solvent and oil them lightly so they will not collect dried paint.

## CLEANING FILTER IN GUN HANDLE

To clean the filter, use a brush dipped in an appropriate solvent. Change or clean filters at least once a day. Some types of latex may require a filter change after four hours of operation.

## CLOGGED FLAT TIP

Should the spray tip become clogged, relieve pressure from hose by following the "Pressure Relief Procedure." Secure gun with the safety latch, take off guard, take out the tip, soak in appropriate solvent & clean with a brush. (Do not use a needle or sharp pointed instrument to clean the tip. The tungsten carbide is brittle and can chip.)

<b>Problem</b>	<b>Cause</b>	<b>Correction</b>
Coarse Spray, Spotty Pattern	Pressure setting low Irratic spray gun/hand motion	Increase pressure setting Use a steady, parallel pass
Excessive Overspray (Fogging)	Pressure setting high Paint over thinned/reduced/cut	Reduce pressure setting Use less thinner/water/reducer
Spray Pattern Excessively Wide	Incorrect fan width selection	Select narrower fan width tip*
Spray Pattern Excessively Narrow	Incorrect fan width selection	Select wider fan width tip*
Excessive Paint Delivery Paint Film Runs/Sags	Large tip orifice for application Paint over thinned/reduced/cut Excessive pressure Spray gun/hand speed slow	Select smaller tip orifice* Use less thinner/water/reducer Reduce pressure setting Increase pass speed
Spray Pattern Rounded and Heavy: Pump Does Not Keep Up	Tip worn beyond use	Replace with new tip*
Spray Pattern Pulsates/Irratic: Pump Does Not Keep Up	Pump worn or malfunctioning	Service pump
Thin or Spotty Coverage (Holidays)	Small tip orifice Spray gun/hand speed fast	Select larger tip orifice* Decrease pass speed
Thin Coverage in Center of Pattern (Fingers)	Tip size larger than pump specs Low pressure setting Pump worn or malfunctioning	Replace with correct tip for pump* Increase pressure setting Service pump
Spray Pattern Irregular, Deflected	Tip orifice partially clogged Tip damaged	Clean tip carefully Replace with new tip*
Excess Paint Builds on Tip Guard	Spray gun excessively close to surface Pressure setting high	Hold gun further from surface sprayed Reduce pressure setting
Drips, Spits From Tip	Valve seat and/or ball in gun head damaged or worn	Service spray gun, replace valve assembly
Tip Clogs Continually	Debris in paint Gun filter missing Coarse filter mesh	Thoroughly strain paint before use Insure gun filter is in handle Use fine mesh filter in gun handle
Gun Filter Clogs Quickly	Debris in paint Pump inlet strainer missing	Thoroughly strain paint before use Do not operate without inlet strainer

**\*See "Tip Selection Guide" in this manual**

# SPRAY TIP SELECTION

Spray tip selection is based on paint viscosity, paint type, and job needs. For light viscosities (thin paints), use a smaller tip; for heavier viscosities (thicker paints), use a larger tip size.

Spray tip size is based on how many gallons of paint per minute can be sprayed through the tip. Do not use a tip larger than the maximum pump flow rate or capacity the sprayer can accommodate. Pump flow rate is measured in gallons per minute (GPM).

<b>REV-TIP<sup>®</sup> for Painting 561-XXX</b> Fan Width (12" from surface)		<b>SPRAY PAINTING TIP - ORIFICE SIZE (Inches)</b>															
in.	(mm)	.007	.009	.011	.013	.015	.017	.019	.021	.023	.025	.027	.029	.031	.035	.039	.041
<b>4-6</b>	<b>102-152</b>		209	211	213	215	217	219	221	223	225	227	229				
<b>6-8</b>	<b>152-203</b>	307	309	311	313	315	317	319	321	323	325	327		335			
<b>8-10</b>	<b>203-254</b>		409	411	413	415	417	419	421	423	425	427	431				
<b>10-12</b>	<b>254-305</b>			511	513	515	517	519	521	523	525	527	531	535			
<b>12-14</b>	<b>305-356</b>			611	613	615	617	619	621	623	625	627	631	635	639	641	
<b>14-16</b>	<b>356-406</b>					715	717		721						739	741	
<b>16-18</b>	<b>406-457</b>					815		819	821				831				
<b>20-24</b>	<b>508-610</b>			<b>NEW WIDE PATTERN REV-TIP</b> ▶					W21	W23	W25						
<b>Gun Filter</b>	C = Coarse F = Fine	F	F	F	F,C	C	C	C	C	C	REMOVE FILTER						
<b>Wood Interior</b>	Lacquer, Varnish Stain, Sealer Enamel	.	.	.	.	.	.	.	.	.	.	.	.	.	.	.	.
<b>Wood Exterior</b>	Exterior Stain Vinyl, Acrylic, Latex			.	.	.	.	.	.	.	.	.	.	.	.	.	.
<b>Masonry</b>	vinyl,oil-base alkyd Latex, Acrylic Block Filler Elastomer				.	.	.	.	.	.	.	.	.	.	.	.	.
<b>Ceiling</b>	Hi Build, Mil White							.	.	.	.	.	.	.	.	.	.
<b>Structural Steel</b>	Heavy Coatings							.	.	.	.	.	.	.	.	.	.
<b>Water Flow Rate</b>	(gal./min.) <small>(water @ 2000psi, 138 bar)</small>		.12	.18	.24	.31	.38	.47	.57	.67	.77	1.03	1.31	1.63	1.80		
	(liters/min.)		.49	.69	.91	1.17	1.47	1.79	2.15	2.54	2.96	3.90	4.98	6.17	6.81		
<b>Paint Flow Rate</b>	(gal./min.) <small>(latex paint @ 2000psi, 138 bar/1.36 spec. gr.)</small>		.10	.15	.21	.27	.33	.40	.49	.58	.66	.88	1.12	1.39	1.54		
	(liters/min.)		.38	.57	.79	1.02	1.25	1.51	1.85	2.20	2.50	3.33	4.24	5.26	5.83		
<b>Pump Minimum Output*</b>	(gal./min.) <small>(liters/min.)</small>		.25	.25	.33	.40	.50	.60	.75	.88	1.0	1.25	1.5	2.0	2.2		
			1.0	1.0	1.25	1.5	1.9	2.3	2.8	3.3	3.8	4.7	5.7	7.5	8.2		

Protected By U.S. Patent No. 6,264,115 Other U.S. & Foreign Patents Applied For.

## PATTERN WIDTH

Thickness of the paint coat per stroke is determined by spray tip "fan width", rate of the spray gun movement, and distance to surface.

## SPRAY TIP SELECTION

Two tips having the same tip size, but different pattern widths will deliver the same amount of paint over a different area (wider or narrower strip). A spray tip with a narrow pattern width makes it easy to spray in tight places.

## SPRAY TIP REPLACEMENT

During use, especially with latex paint, high pressure will cause the orifice to grow larger. This destroys the pattern.

Replace tips before they become excessively worn. Worn tips waste paint, cause overspray, make cutting-in difficult, and decreases sprayer performance.



**NEW Double Orifice** design for lower pressure airless spraying when you need finer atomization for a smoother finish on interior trim, cabinetry, shutters, and doors.

Fan Width Inches	(mm)	Orifice Size	
		.012	.014
<b>4-6</b>	<b>102-152</b>	212	214
<b>6-8</b>	<b>152-203</b>	312	314
<b>8-10</b>	<b>203-254</b>	412	414

# ELECTRIC MOTOR MAINTENANCE

**1. LUBRICATION** - This motor is supplied with prelubricated ball bearings, lubricated for life of bearing.

**2. MOTOR BRUSHES** - These need periodic inspection and replacement as wear indicates. Brushes for the Leeson motor (LP540/690) PN 331-131 have an initial length of 3/4" and must be replaced when worn to 3/8." Brushes for the Airlessco DC Motor (LP400/460) PN 331-778 have an initial length of 13/16" and must be replaced when worn to 1/4".

**3. TO CHANGE THE BRUSHES**, follow the procedures below:

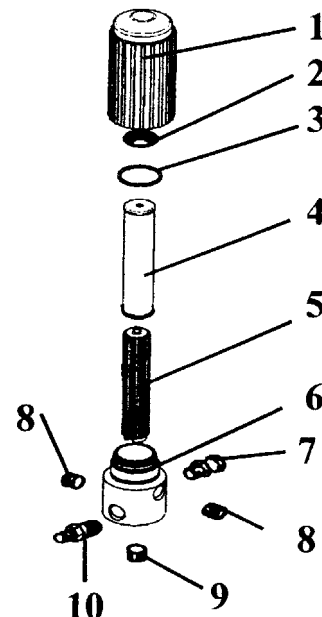
- a. Unplug the machine.
- b. Remove brush access plates at the rear of the motor.
- c. Loosen the screw holding the brush terminal and remove the brush lead.
- d. Push the brush retainer clip in and remove.
- e. Remove the worn brushes (one on each side of motor).
- f. Install new brushes in reverse order and replace plates.

**NOTE:** For longer life, new brushes need to have a "run in" period. After installing a new brushes, set up the machine for spraying. Use a bucket of water and Airlessco Pump Conditioner mixture, a 50 foot x 1/4" airless hose, airless gun with 0.017 tip on Gun. Turn the Prime/PR Control Valve to the Prime position and turn the unit on. Turn the Pressure Control Knob to maximum pressure (fully CW position) and let the pump cycle at high speed in the prime position for 20 minutes. This will allow the brushes to "run in" properly.

# MANIFOLD FILTER - PN 111-200-99

FIGURE 10 PARTS LIST		
ITEM #	PART #	DESCRIPTION
	111-200-99	Filter Ass'y
1	111-202	Base
2	301-356	Spring
3	106-007	O-Ring
4	111-204	Filter 60 Mesh
5	111-203	Support
6	111-201	Base
*7	100-159	Swivel
8	100-129	Plug 3/8" (2)
9	100-028	Plug 1/4"
10	100-109	Nipple 3/8 x 1/4

**FIGURE 10**



\* LP690 & 810E come equipped with fittings 100-201 and 169-010

# FIELD TROUBLESHOOTING

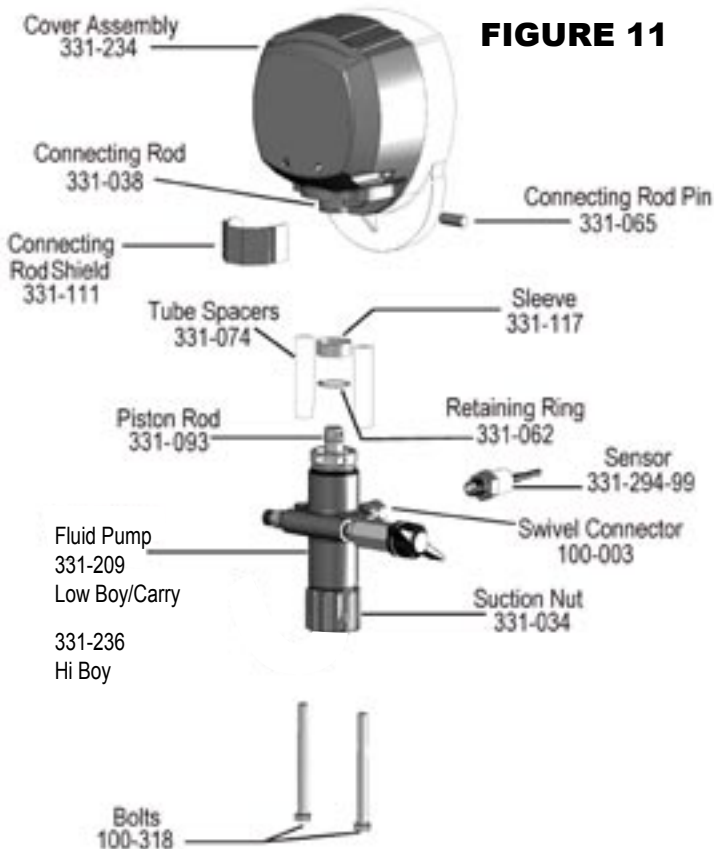
<b><u>PROBLEM</u></b>	<b><u>CAUSE</u></b>	<b><u>SOLUTION</u></b>
<b>Unit doesn't prime</b>	<ul style="list-style-type: none"> <li>➤ Airleak due to:               <ul style="list-style-type: none"> <li>• Loose Suction Nut</li> <li>• Worn O-Rings</li> </ul> </li> <li>• Hole in Suction Hose</li> <li>➤ Stuck or Fouled Balls</li> </ul>	<ul style="list-style-type: none"> <li>• Tighten Suction Nut</li> <li>• Replace O-Ring (106-011) on suction seat, &amp; O-Ring (106-020) below suction seat</li> <li>• Replace Suction Hose (331-290)</li> <li>➤ Service outlet valve suction assembly</li> </ul>
<b>Unit primes but has no or poor pressure</b>	<ul style="list-style-type: none"> <li>➤ Pressure set too low</li> <li>➤ Filter(s) are clogged</li> <li>➤ Outlet Valve fouled/worn</li> <li>➤ Prime/Pressure Relief valve bypassing</li> <li>➤ Packings and/or piston worn</li> </ul>	<ul style="list-style-type: none"> <li>➤ Turn up pressure</li> <li>➤ Clean or replace gun filter, inlet filter and/or manifold filter</li> <li>➤ Service outlet valve</li> <li>➤ Clean or replace primve valve</li> <li>• Tighten packing nut</li> <li>• Repack unit</li> </ul>
<b>Unit does not maintain good spraying pressure</b>	<ul style="list-style-type: none"> <li>➤ Blown spray tip</li> <li>➤ Packings and/or piston worn</li> <li>➤ Upper Seat worn</li> </ul>	<ul style="list-style-type: none"> <li>➤ Replace spray tip</li> <li>➤ Repack unit</li> <li>➤ Replace upper seat</li> </ul>
<b>Unit does not run</b>	<ul style="list-style-type: none"> <li>➤ Blown fuse</li> <li>➤ Electrical failure</li> </ul>	<ul style="list-style-type: none"> <li>➤ Replace fuse               <ul style="list-style-type: none"> <li>• 15A SlowBlow (pn. 331-256) - 4 Series</li> <li>• 20A SlowBlow (pn. 331-328) - 5&amp;6 Series</li> </ul> </li> <li>➤ See electrical troubleshooting - 4 Series &amp; 5-6 Series</li> </ul>

# SERVICING THE FLUID PUMP

**NOTE:** Check everything in the Troubleshooting Chart before disassembling the Fluid Pump.

## Fluid Pump Removal - Refer to Figure 11

1. Follow the Pressure Relief Procedure page 10.
2. Flush the material you are spraying out of the machine.
3. Remove the connecting rod shield (331-111).
4. Move the piston rod (331-093) to its lowest position by cycling pump slowly or by rotating the motor fan.
5. Disconnect the sensor (331-294-99) by holding it in place with a 7/8" wrench and unscrewing the swivel connector (100-003) with an 11/16" wrench.  
**DO NOT TURN THE SENSOR.**
6. Remove the retaining ring (331-062) from the connecting rod (331-038) and slide the sleeve (331-117) down revealing the connecting rod pin (331-065).
7. Remove the suction tube assembly from the fluid pump by unscrewing the suction nut (331-034) with the packing adjustment tool.
8. Using a 1/2" wrench unscrew the two bolts (100-318) from the cover assembly 331-234. The fluid pump (331-209) will be hanging loosely at this point.
9. Remove the connecting rod pin (331-065) out of the connecting rod (331-038), allowing the removal of the fluid pump (331-209) from the machine.



## Fluid Pump Reinstallation - Refer to Figure 11 & 14

1. Loosen the packing nut and ensure that the piston rod (331-093) is in its upper position in the fluid pump body. Slip the sleeve (331-117) & the retaining ring (331-062) over the piston rod.
2. Push the piston rod up into the connecting rod (331-038) & align the holes. Insert the connecting rod pin (331-065) through the connecting rod & piston. Slip the sleeve over the connecting rod pin and insert the retaining ring into the groove on the connecting rod.
3. Push the two bolts (100-318) through the tube spacers (331-074) & screw them into the cover assembly (331-234). Using a 1/2" wrench, tighten the two bolts evenly (alternating between them) until you reach 20 ft-lbs.
4. Reassemble the lower suction valve assembly by placing the suction seat assembly: O-ring (106-011), suction ball (331-030) and suction ball guide (331-029) in the suction nut (331-034) and screw onto the fluid pump body.
5. Reconnect the sensor (331-294-99) to the fluid pump body. Hold the sensor with a 7/8" wrench while tightening the swivel connector (100-003) with an 11/16" wrench.  
**DO NOT TURN THE SENSOR.**
6. Start the machine and operate slowly to check the piston rod for binding. Adjust the two bolts, holding the fluid pump body to the cover assembly, if necessary. This will eliminate any binding.
7. Tighten the packing nut counter clockwise until resistance is felt against the Belleville Springs, then go 3/4 of a turn more. Put five drops of Airlessco Throat Seal Oil into the packing nut.
8. Run the machine at full pressure for several minutes. Release the pressure by following the Pressure Relief Procedure & readjust the packing nut per step 7 above.
9. Install the connecting rod shield (331-111) so that the small hole is in the upper right hand corner.

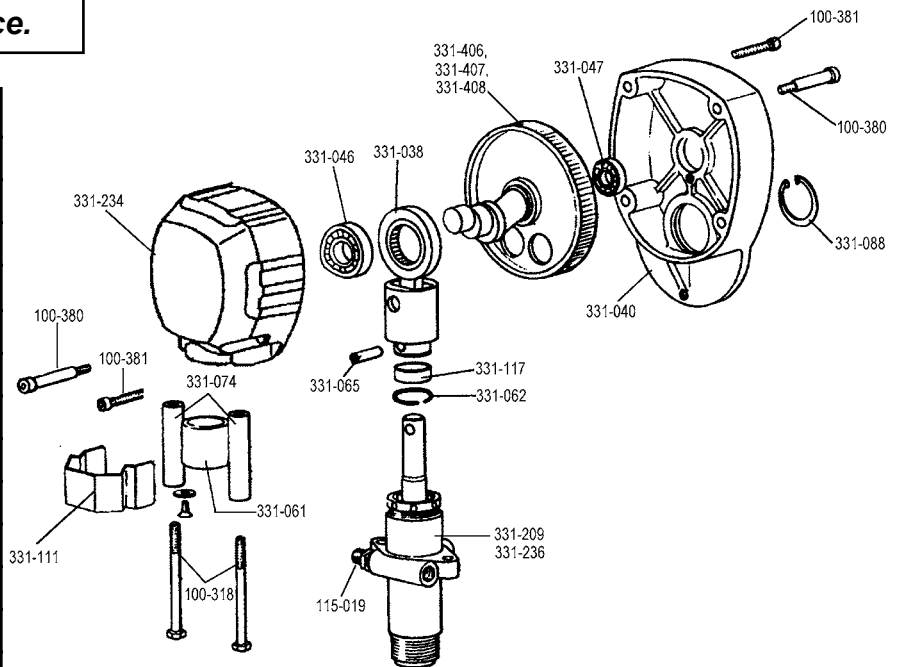
# GEAR AND PUMP ASSEMBLY

**WARNING** - Do not operate machine without cover guard in place.

Part Number	Description
100-318	Bolt (2)
100-380	Shoulder Bolt (2)
100-381	Bolt (2)
115-019	Hose Connector (1/4 NPSXNPT)
331-038	Crosshead Assembly
331-040	Gearbox Casting *
331-046	Bearing
331-047	Bearing
331-061	Sleeve Bearing
331-062	Retaining Spring
331-065	Pin
331-074	Tube Spacer (2)
331-088	Retaining Ring
331-111	Cover Guard
331-117	Sleeve
331-209	Pump Ass'y - Carry/LoBoy
331-234	Cover
331-236	Pump Ass'y - HiBoy
331-406	Gear Crank (4 Series)
331-407	Gear Crank (5 Series)
331-408	Gear Crank (6 Series)

\*NOTE: Can be ordered separately, but is included with Motor Ass'y (Part No. 331-490, 331-068)

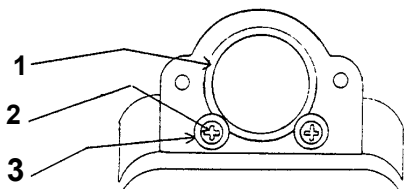
**FIGURE 12**



## **Servicing Gear Box Assembly**

1. Remove fluid pump as per "Fluid Pump Disconnect" procedures.
2. Remove frame from the gearbox by loosening the four mounting screws.
3. Refer to Figure 12. Separate cover assembly from box by removing bolts from front of cover & back of box & shoulder bolts from front of cover & back of box.
4. Lay unit on its back and disassemble gearbox.
5. Inspect bearings, Crosshead Assembly, Gearcrank & sleeve bearing inside cover assembly for wear/damage. Replace worn/damaged parts.
6. If gear grease needs replacing, replace with gear grease (Part No. 331-132).
7. Clean mating surfaces of cover and box thoroughly. Use Part No. 105-331 BLUE XS™ ADVANCED RTV SILICONE INSTANT GASKET.
8. Reassemble in reverse order.

## **GEARBOX SLEEVE BEARING REPLACEMENT**



**NOTE:** When replacing item (1), cover outside of sleeve with clear silicone prior to inserting into cover assembly.

### **FIGURE 10 PARTS LIST**

ITEM #	PART #	DESCRIPTION
1	331-061	Sleeve Bearing
2	331-103	Washers (2)
3	331-197	Screws (2)

# Servicing the Piston Rod - Outlet Valve

## DISASSEMBLY OF THE OUTLET VALVE

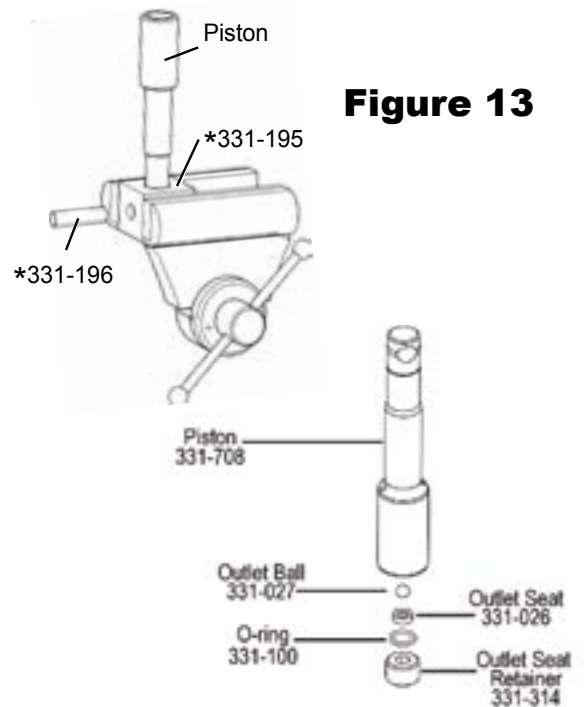
### REFER TO FIGURE 13

1. Disconnect the Fluid Pump.
2. Place piston holder (331-195) in a vise. Slide piston into the holder & lock in place with a 3/8" dowel (331-196).
3. Use a 1/4" allen wrench to unscrew the outlet seat retainer (331-314) from the piston.
4. Remove the outlet seat (331-026), O-ring (331-100) and outlet ball (331-027).
5. Inspect outlet ball & seat for wear. Replace as necessary.
6. While piston is still locked in the holder, install parts back into the piston in the following order:

***ball, outlet seat and O-ring***

Before reinstalling the outlet seat retainer, apply two drops of Loctite No. 242 (blue) on the threads & torque to 20 ft-lbs.

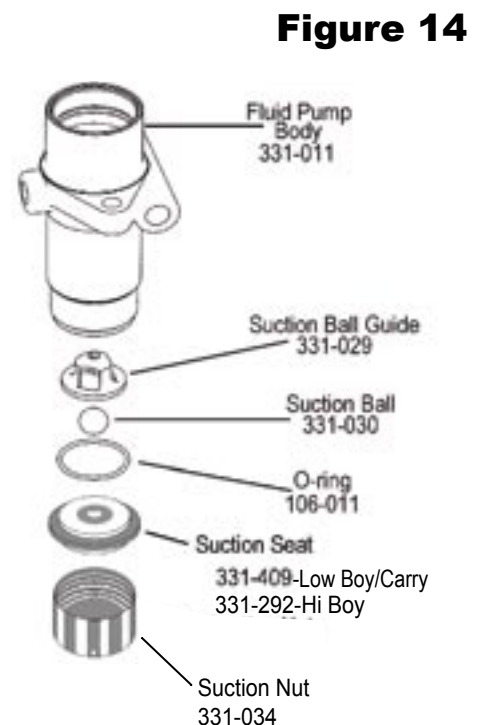
\* Available in LP tool kit PN 188-397



# Servicing the Suction Assembly

### Refer to Figure 14

1. Unthread and remove suction nut from the fluid pump body.
2. Remove suction seat (331-409), O-ring (106-011), suction ball (331-030) and suction retainer (331-029).
3. Clean all parts and inspect them for wear or damage, replacing parts as needed.
4. Clean inside of the fluid pump body.
5. Reassemble lower suction valve assembly by placing the suction seat (331-409), O-ring (106-011), suction ball (331-030) & suction ball guide (331-029) in the suction nut (331-034) & screw onto fluid pump body.



# Packing Replacement Procedures

## Replacement Instructions:

### Fluid Pump Removal - Refer to Figure 11

1. Follow the Pressure Relief Procedure above.
2. Flush material you are spraying out of the machine.
3. Remove the connecting rod shield (331-111).
4. Move the piston rod (331-093) to its lowest position by cycling pump slowly or by rotating the motor fan.
5. Disconnect the sensor (331-294-99) by holding it in place with a 7/8" wrench & unscrewing the swivel connector (100-003) with an 11/16" wrench.

#### **DO NOT TURN THE SENSOR.**

6. Remove the retaining ring (331-062) from the connecting rod (331-038) and slide the sleeve (331-117) down revealing the rod pin (331-065).
7. Remove the suction tube assembly from the fluid pump (331-708) by unscrewing the suction nut (331-034) with the packing adjustment tool.
8. Using a 1/2" wrench unscrew the two bolts (100-318) from the cover assembly 331-234). The fluid pump (331-209) will be hanging loosely at this point.
9. Remove the connecting rod pin (331-065) out of the connecting rod (331-038), allowing the removal of the fluid pump (331-209) from the machine.

### Disassembly of the Fluid Pump - Figure 15

1. Unscrew & remove the packing nut (331-037).
2. Push the piston rod (331-708) down through the packings & out of the pump.
3. Now push the packing removal tool (187-249) up through the pump & remove from the top bringing packings, spacer & springs along with it, leaving fluid body (331-011) empty.

*\*Make sure all old packings & glands have been removed from fluid pump.*

4. Clean inside of fluid body (331-011).
5. Disassemble all parts & clean for reassembly. Discard any old packings.
6. Lubricate leather packing in lightweight oil for 10 minutes prior to reassembly.











### Disassembly of the Outlet Vavle - Figure 13

1. Place piston holder (331-195) in a vise. Slide piston into the holder & lock in place with a 3/8" dowel.
2. Use a 1/4" allen wrench to unscrew the outlet seat retainer (331-026) from the piston.
3. Remove the outlet seat (331-026), O-ring (331-100) and outlet ball (331-027).
4. Inspect outlet ball & seat for wear. Replace as necessary.
5. While piston is still locked in the holder, install parts back into the piston in the following order:

#### **ball, outlet seat and O-ring**

Before reinstalling the outlet seat support, apply two drops of Loctite No. 242 (blue) on the threads & torque to 20 ft-lbs.

## REASSEMBLY - Figure 15 & 16

1. Take lower male gland (331-014) & place it down on the flat side. 
2. Take three of the lower polyethylene packings (331-016) & two of the leather packings (331-306) & place onto the male gland in the following order with the inverted side down :  polyethylene, leather, polyethylene, leather, polyethylene.
3. Take the female adaptor (331-305), which is inverted on both sides, & place it on top of your assembled lower packings.
4. Follow step 2 above with your packings inverted side up. 
5. Take the second lower male gland and place it on top of your assembled packings with the rounded side down. 
6. Take assembled glands & packings (13 pieces) & slide on to the lower half of the piston.
7. Take the spacer (331-018) & slide over the top of the piston (it doesn't matter which direction it sits), falling onto lower packings.
8. Take three Belleville Springs (331-025) & slide over the top of the piston in the following order:
  - \* First spring, curve facing down 
  - \* Second spring, curve facing up 
  - \* Third spring, curve facing down 
9. Take the upper male gland (331-022) & place it rounded side up. 
10. Take three upper polyethylene packings (331-023) & two leather packings (331-307) & assemble with inverted side down , on to the male gland in the following order: polyethylene, leather, polyethylene, leather, polyethylene.
11. Take upper female gland (331-021) & place on top of the assembled upper packings with the inverted side down. 
12. Take assembled upper glands & packings (7 pieces) & slide on over the top of the piston, making sure inverted sides are down.
13. Take the packing holder (331-019) & replace the white O-ring (106-009) & the black O-ring (106-010) with new ones from the packing kit.
14. Slide the packing holder over the top of the upper packings so they fit inside.
15. Lubricate inside of the fluid pump body & the outside of the packings with a light weight oil.
16. Slide completed assembly into fluid pump body (331-011).

*\* To keep packings secured in correct position, hold the pump body upside down & push the completed assembly upwards into the pump body. Once placed inside, tilt pump body back up to keep all pieces in.*

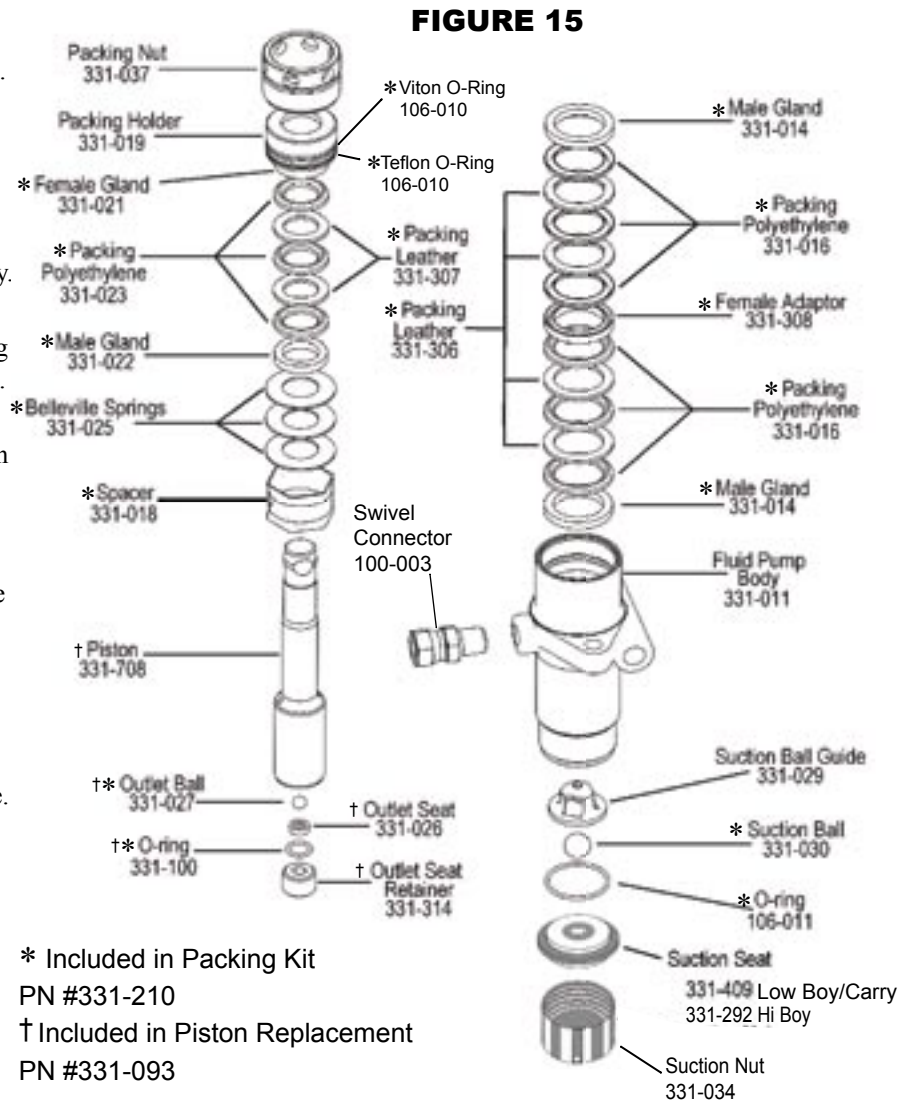
17. Tighten packing nut (331-037) onto the top of the fluid pump body & tighten until you feel slight resistance against the Belleville Springs (331-025). Using the Packing Adjustment Tool (189-211), tighten another 3/4 of a turn.

### Fluid Pump Reinstallation - Figure 11 & 14

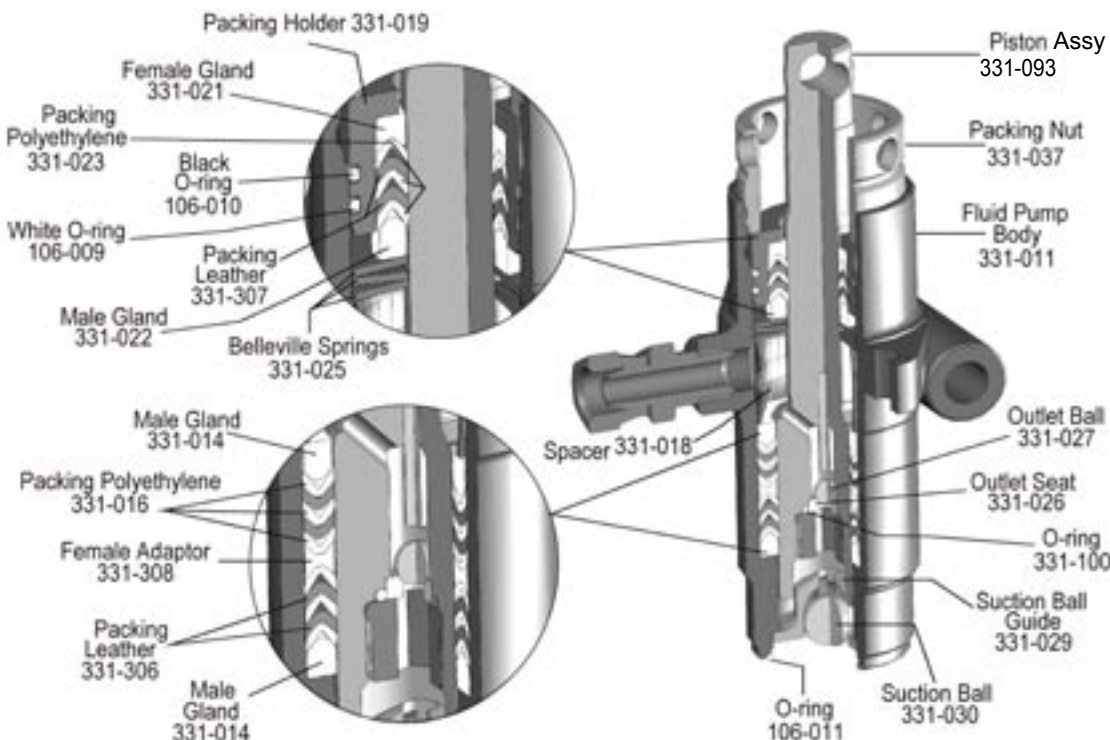
1. Loosen packing nut & ensure that the piston rod (331-093) is in its upper position in the fluid pump body (331-209). Slip the sleeve (331-117) & the retaining ring (331-062) over the piston rod.
2. Push piston rod up into the connecting rod (331-038) & align the holes. Insert the connecting rod pin (331-065) through the connecting rod & piston. Slip the sleeve up over the connecting rod pin & insert retaining ring into the groove on the connecting rod.

# Packing Replacement Procedures (Continued)

- Push the two bolts (100-318) through the tube spacers (331-074) & screw into the cover assembly (331-234). Using a 1/2" wrench, tighten the two bolts evenly (alternating between them) until you reach 20 ft-lbs.
- Reassemble lower suction valve assembly by placing the suction seat (331-409) O-ring (106-011), suction ball (331-030) and suction ball guide (331-029) in the suction nut (331-034) & screw onto the fluid pump body.
- Reconnect the sensor (331-294-99) to the fluid pump body. Hold sensor with a 7/8" wrench while tightening the swivel connector (100-003) with an 11/16" wrench.  
**DO NOT TURN THE SENSOR.**
- Start the machine & operate slowly to check the piston rod for binding. Adjust the bolts, holding the fluid pump body to the cover assembly, if necessary. This will eliminate any binding.
- Tighten packing nut counter clockwise until resistance is felt against the Belleville Springs, then go 3/4 of a turn more. Put five drops of Airlessco Throat Seal Oil into the packing nut.
- Run the machine at full pressure for several minutes. Release the pressure by following the Pressure Relief Procedure & readjust the packing nut per step 7 above.
- Install the connecting rod shield (331-111) so that the small hole is in the upper right hand corner.

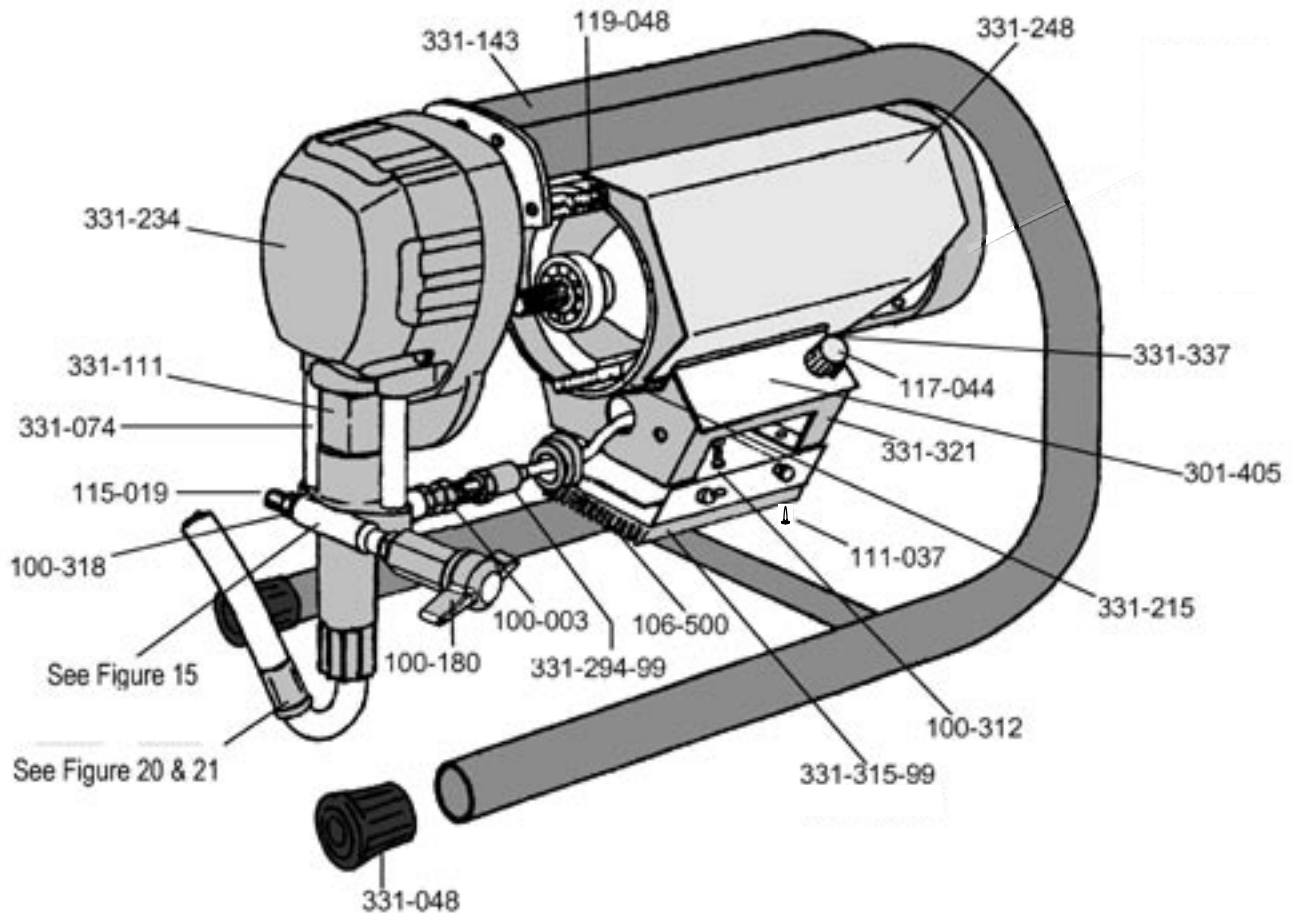


**FIGURE 16**



# CARRY FRAME MODELS

**FIGURE 17**

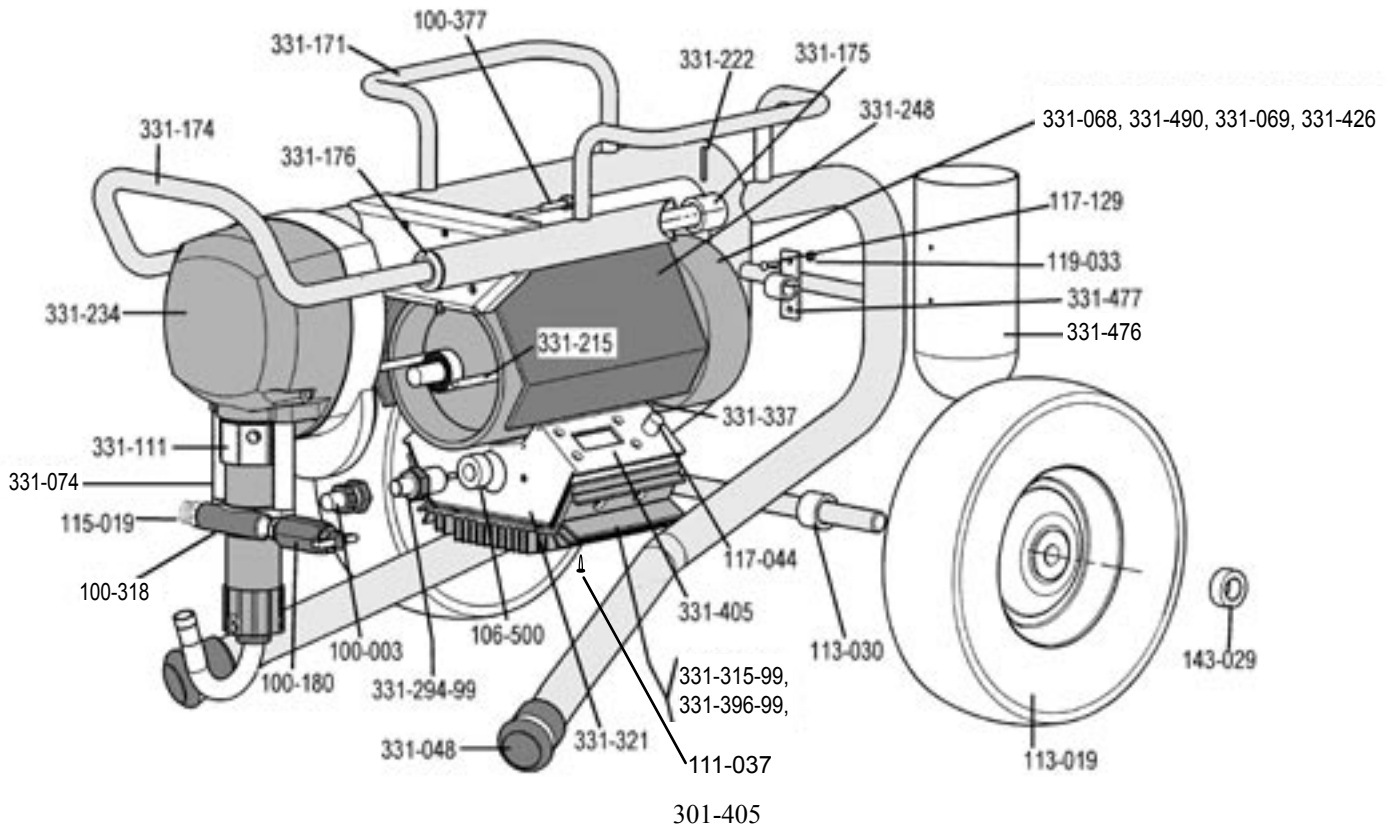


Part Number	Description
100-003	Swivel
100-180	Prime P/R Valve
100-312	Screw (4)
100-318	Bolt (2)
106-500	Sensor Seal
111-037	Heatsink Screw (4)
115-019	Hose Connector (1/4 NPSXNPT)
117-044	Knob
117-090	Fan Cover Screws (3)
119-048	Screw (4)
301-191	Fan Retaining Clip
301-405	Blank Plate for LCD Panel
331-048	Rubber Boot (2)
331-068	.8 HPDC Motor (5/6 Series)
331-074	Tube Spacer (2)

Part Number	Description
331-111	Shield
331-143	Frame
331-212	Fan
331-213	Fan Cover
331-215	Screw (LP 5/6 Only)
331-234	Cover
331-248	Cover (690 Models)
331-294-99	Sensor
331-315-99	Press. Ass'y
331-490	.6 Airlessco DC Motor (4 Series)
331-321	Terminal Box
331-337	Rubber Edge (2) (690 Only)
331-398	Brush Spring (2) (5/6 Series)
331-131	Motor Brush (2) (5/6 Series)
331-778	Motor Brush (2) (4 Series)

# LO-BOY MODELS

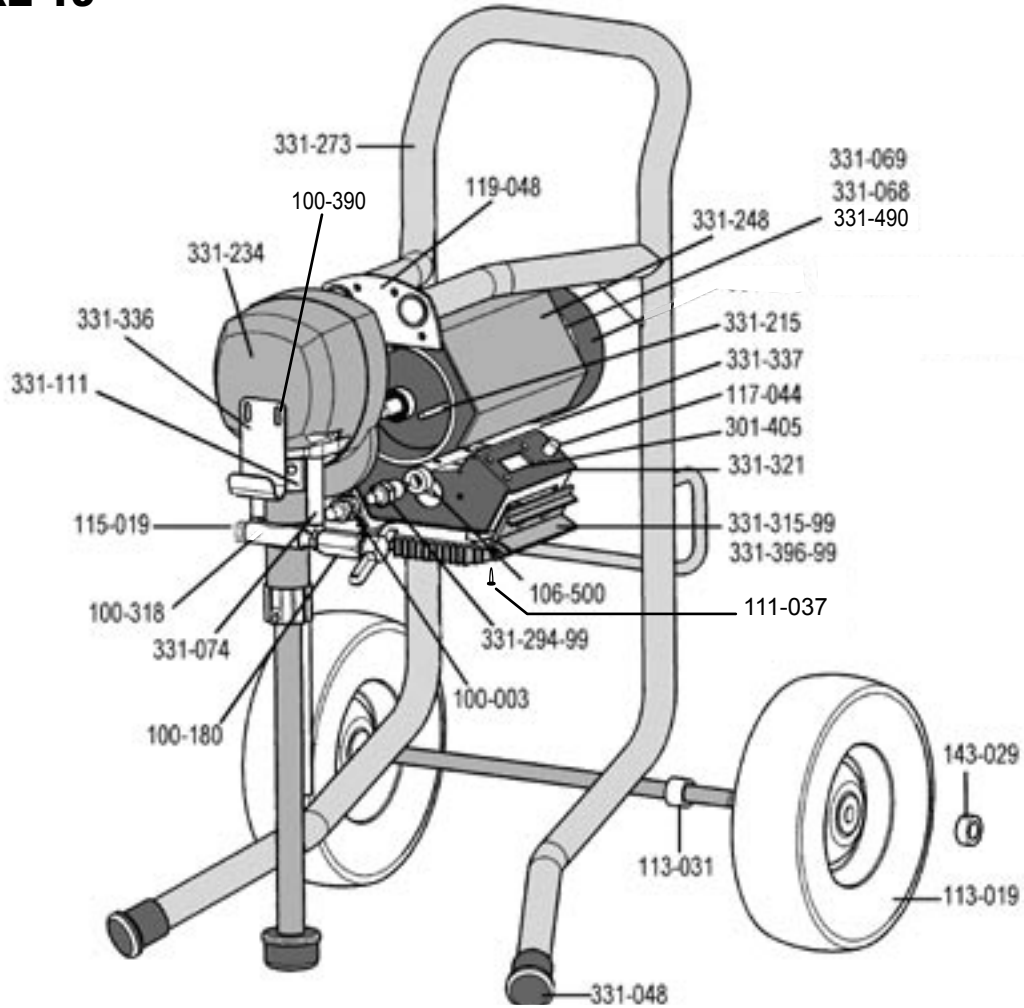
**FIGURE 18**



Part Number	Description	Part Number	Description
100-003	Swivel	331-074	Tube Spacer (2)
331-476	Cup Assembly	331-111	Shield
100-180	Prime Valve	331-171	Frame
100-318	Bolts (2)	331-174	Handle
100-377	Screw (4)	331-175	Spacer (2)
106-500	Sensor Seal	331-176	Bushing (2)
111-037	Heatsink Screws (4)	331-212	Fan
113-019	Wheel 10" (2)	331-213	Fan Cover
113-030	Spacer (2)	331-215	Bolt (5/6 Series)
115-019	Hose Connector (1/4" NPSXNPT)	331-222	Pin (2)
117-044	Knob	331-234	Cover
117-090	Fan Cover Screws (3)	331-248	Motor Cover (690 Only)
117-129	Screw (2)	331-294-99	Sensor
119-033	Nut (2)	331-315-99	Pressure Ass'y 110V
143-029	Collar (2)	331-490	.6 Airlessco DC Motor (4 Series)
301-191	Fan Retaining Clip	331-321	Terminal Box
331-048	Rubber Boot (2)	331-337	Rubber Edge (2) (690 Only)
331-068	.8 HP DC Motor 110V (5/6 Series)	331-396-99	Pressure Ass'y 230V
331-069	.75 HP DC Motor 230V (5/6 Series)	301-405	Blanking Plate, LCD Panel
331-426	.6 HP DC Motor 230V (4 Series)	331-477	Cup Support

# HI-BOY MODELS

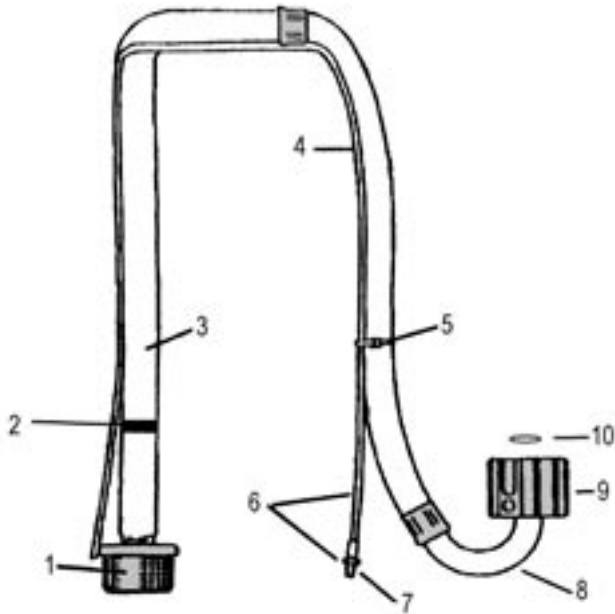
**FIGURE 19**



Part Number	Description	Part Number	Description
100-003	Swivel	331-069	.75 HP DC Motor 230V (5/6 Series)
100-180	Prime Valve	331-074	Tube Spacer (2)
100-318	Bolt (2)	331-111	Shield
100-390	Screw (2)	331-212	Fan
106-500	Sensor Seal	331-213	Fan Cover
111-037	Heatsink Screws	331-215	Bolt (5/6 Series)
113-019	Wheel 10" (2)	331-234	Cover
113-031	Spacer (2)	331-248	Motor Cover (690 Only)
117-044	Knob	331-273	Frame
117-090	Fan Cover Screw (3)	331-294-99	Sensor
119-048	Screw (4)	331-315-99	Pressure Ass'y 110V
143-029	Collar (2)	331-490	.6 Airlessco DC Motor (4 Series)
115-019	Hose Connector (1/4" NPSXNPT)	331-321	Terminal Box
301-191	Fan Retaining Clip	331-336	Pail Hook
301-405	Cover Plate for LCD Opening	331-337	Rubber Edge (690 Only)
331-048	Rubber Boot	331-396-99	Pressure Ass'y 230V
331-068	.8 HP DC Motor 110V (5/6 Series)		

# SUCTION ASSEMBLIES

**FIGURE 20 - LoBoy & Carry Frames**



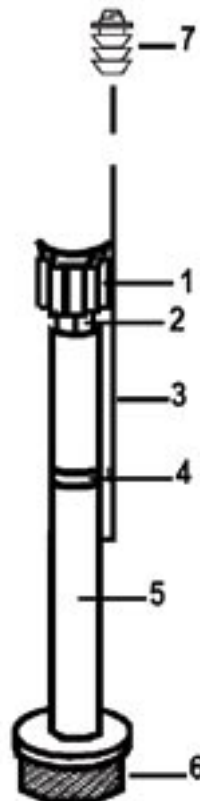
**PN 331-238 (Lo-Boy & Carry Chassis)**

ITEM #	PART #	DESCRIPTION
1	331-217	Inlet Strainer
2	331-135	Spring Clip
3	331-290	Suction Hose Ass'y (inc. strainer)
4	331-425	Bypass Hose
5	111-016	Nylon Tie
6	331-231	Bypass Hose Ass'y
7	331-090R	Fitting
8	331-035	Suction Elbow
9	331-034	Suction Nut
10	106-020	O-Ring Teflon

**FIGURE 21 - HiBoy Frame**

**PN 331-284 (Hi-Boy Chassis)**

FIGURE 21 PARTS LIST		
ITEM #	PART #	DESCRIPTION
1	331-034	Suction Nut
2	331-292	Suction Seat Ass'y
3	301-348	Bypass Hose
4	116-103	Spring Clip
5	331-400	Inlet Tube
6	141-008	Inlet Strainer
7	331-090R	Fitting



# ELECTRICAL BOARD CALIBRATION

**Note: Anytime a sensor, pressure control assembly (board) or both are replaced, the following calibrations must be performed.**

## **1. ZERO CALIBRATION**

1. Place prime/pressure relief valve in the prime (open) position.
2. Set the pressure control knob to the minimum setting (CCW).
3. Remove the screws and lower the pressure control assembly.
4. Ensure the jumper is on the "P-ZR" terminal. *Note: This jumper comes with a new pressure control assembly (board) and is installed on the "P-ZR" terminals. If you are "Zero Calibrating" a pressure control assembly presently in the unit, remove jumper from single terminal P-ZR and place on both terminals P-ZR. When Zero Calibration is complete, replace jumper on a single terminal of P-ZR.*
5. Turn machine "ON" and ensure it is not cycling.
6. If the yellow zero light on the electrical board is ON, use an insulated screwdriver to turn the "ZERO" trimpot counter-clockwise until the light goes out. Then turn it clockwise until the light just comes back on. If so equipped, look at the LCD Display and if "0000" is showing the Zero Calibration is complete. If the display shows more than "0000", turn the Zero Trimpot CCW until "0000" is showing. If "-- -- --" is showing, turn the zero trimpot CW until "0000" is displayed.
7. If the yellow light is OFF, turn the "Zero" trimpot clockwise, just until the light comes on and stop. Confirm "0000" is displayed.

***NOTE: If the yellow light remains constantly "ON", or "OFF" during this calibration, the sensor is defective and should be replaced.***

8. IMPORTANT: When calibration is complete, move jumper from both "PZ-R" terminals to single terminal on P-ZR.

## **2. PRESSURE CALIBRATION**

1. Complete the ZERO calibration, as per "ZERO CALIBRATION" prior to commencing this calibration.
2. Attach a 50', 1/4" airless hose, airless gun with 0.017 tip and a 5000 psi glycerin filled pressure gauge to the pump.
3. Place the suction tube into a bucket of Coro-chek and water.
4. Turn prime/pressure relief valve to the prime (open) position.
5. Turn pressure control knob clockwise until machine starts to prime.
6. Place the prime/pressure relief valve in the pressure (closed) position.
7. While watching pressure gauge, slowly adjust the pressure trimpot (clockwise to increase and counterclockwise to decrease) until the maximum static pressure is 3000 psi, with the pressure control knob fully clockwise. Trigger the gun several times to ensure pressure returns to 3000 psi.

## **3. LIQUID CRYSTAL DISPLAY (LCD) CALIBRATION** ( If so equipped)

1. Complete the "ZERO CALIBRATION" and "PRESSURE CALIBRATION" procedures prior to commencing this calibration.
2. Turn pressure control knob up until system pressure is above 2500 psi (as indicated on glycerin filled pressure gauge) and the machine is not cycling.
3. Use an insulated screwdriver to adjust the Set trimpot. Turn trimpot CCW until it clicks, then adjust to match pressure against pressure gauge reading.
4. Move the pressure control knob to different settings and trigger the gun several times to ensure that the LCD continues to match the pressure gauge reading.

# ELECTRICAL BOARD CALIBRATION (CONTINUED)

## 4. PHASE LIMIT TRIMPOT CALIBRATION

### Formerly known as the Low Voltage or Master Voltage Calibration

1. Attach a 50', 1/4" airless hose, airless gun with .017 tip and a 5000 psi glycerin filled pressure gauge to the pump.
2. Place the suction tube into a bucket of Pump Conditioner and water.
3. Turn pump ON and turn up pressure control until the machine starts to prime.
4. Place the prime/pressure relief valve in the pressure (closed) position.
5. Pressurize pump to 600 psi.
6. Trigger the gun several times noting the deadband (the amount of pressure drop before the pump rebuilds to set pressure).
7. If deadband is greater than 100 psi, adjust the low pressure voltage trimpot so that the deadband is less than 100 psi and the pressure increase after the gun trigger is released is less than 200 psi. These pressures are guidelines and may vary slightly from pump to pump.
8. Reattach Pressure Control Assembly being careful not to pinch wires.

***Note: The 331-315-99 pressure control assembly has a reddish brown terminal labelled "Inhibit Switch". At all times there should be a jumper on the two left terminals, which are the closest to the "S2" connection. Also on the Revision E is a terminal labelled "ON-SL". This terminal should never have a jumper on it.***

# TROUBLESHOOTING - Machine does not start

## CAUSE

## STEPS (SEE FIGURE 22)

### Control Settings

**STEP 1:** After making sure that the machine is plugged into the wall, verify that the on-off switch is in the ON position and that the pressure control knob is turned all the way to the right (clockwise for maximum pressure).

### Fuse

**STEP 2:** Using your multi-meter, test the fuse for continuity or replace with a new fuse. If the fuse reads good, move on to step three.

**STEP 3:** Using a Phillips Head screwdriver, remove the four screws holding the pressure control assembly. Locate the light on the board indicating there is power (it will be red or green). If light is OFF proceed to step four. If light is ON go to step six.

### Power Source

**STEP 4:** Locate the L1 and L2 terminals on the board, and then using your multi-meter check to make sure you have 110 volts AC across the two terminals (the cord wires will still be attached). If there is no voltage at these leads, there is no power getting to the machine. Check your power source (outlet, circuit breaker, extension cord, and power cord). If you have AC voltage at the L1 and L2 terminals, go to step 5.

### Thermal Overload

**STEP 5:** Disconnect the two red motor leads (S1 & S2) and test for continuity between them. No continuity means that the thermal coupler has opened due to excessive motor heat. If the motor is still hot to the touch, allow it to cool and then retest. If the motor is cool and there is not continuity on the red leads, contact your local Leeson repair facility to repair/replace the thermal coupler. Continuity shows that the motor's thermal coupler has not tripped. Proceed to step six.

### Pressure Control Assembly (Board)

**STEP 6:** If everything checks out in steps one through five and the power indicating light is still out, replace the pressure control assembly.

### Motor

**STEP 7:** Remove the motor brush covers and turn the machine on. Set the potentiometer (POT) at maximum pressure and check for DC voltage across both brush terminals. You should read greater than 80 volts DC. IF YOU DO NOT HAVE DC VOLTAGE GO TO STEP EIGHT. If you have DC voltage, turn the machine off and unplug it from the wall. Check to make sure that the brushes are making good contact with the armature. Replace the brushes if they are less than 3/8" long. If the brushes are good, replace the motor.

### Sensor

**STEP 8:** Plug another sensor into the board and perform the zero calibration procedure. If the machine starts to run, the sensor was bad. If there is no replacement sensor available, use a multi-meter to test the resistance across the red and black wires of the sensor (be sure to test at the plug). You should read 1.5 - 3.5k ohms. A faulty sensor usually reads no continuity (open). If the sensor passes all the tests move to step nine.

### Pressure Control Knob (Potentiometer)

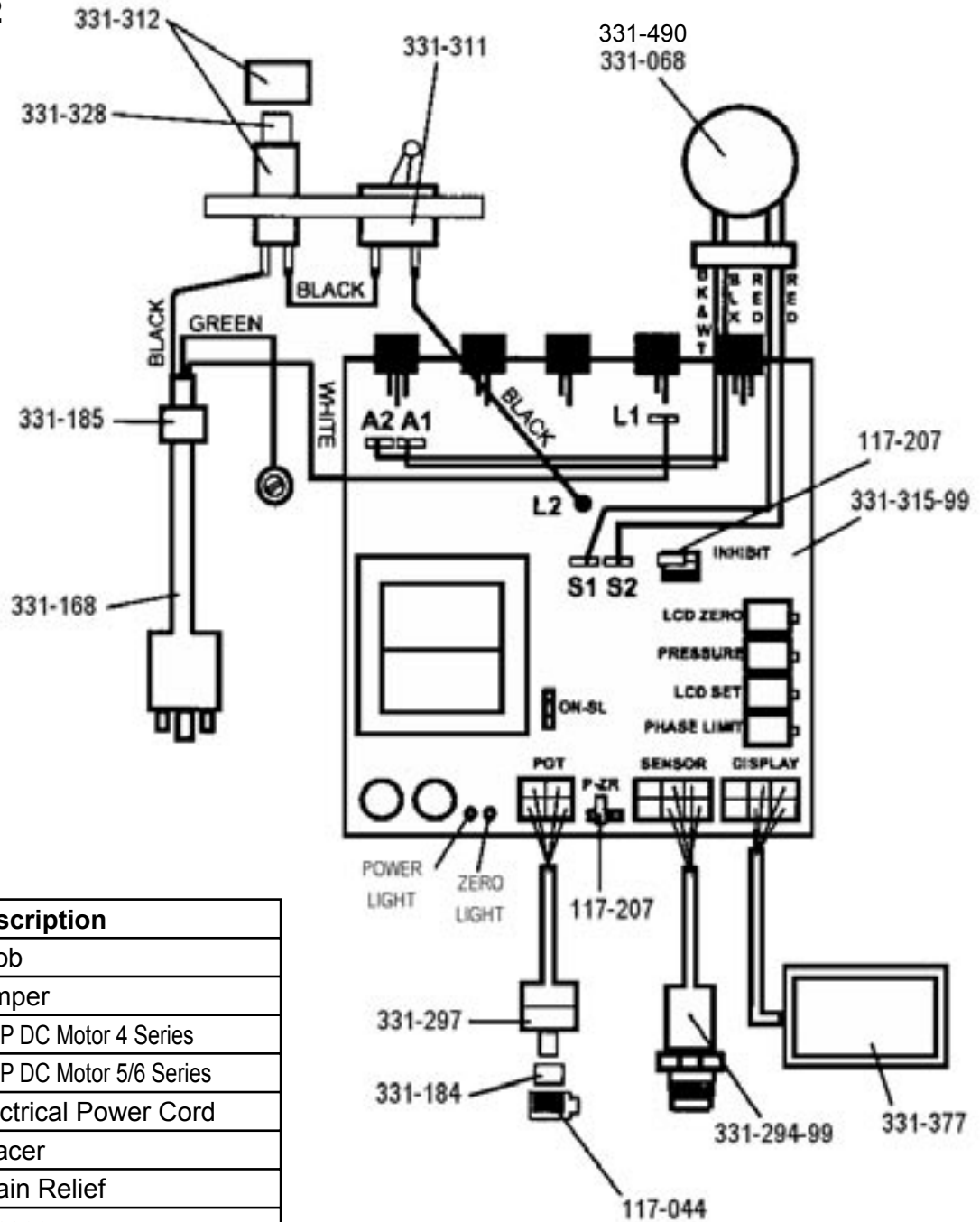
**STEP 9:** Plug another potentiometer (POT) into the control board. If the machine starts, the old POT is bad. When replacement POT is not available, remove the POT lead (with the machine turned off) from the control board and test the resistance between the red and black wires (be sure to test at the plug). The resistance should read between 8-12k ohms if it is outside of this range replace the POT.

### Pressure Control Assembly (Board)

**STEP 10:** If you do not have DC voltage at the motor brushes and all of the components check out fine in steps eight and nine, replace the pressure control assembly.

# ELECTRICAL SYSTEM

**FIGURE 22**



Part Number	Description
117-044	Knob
117-207	Jumper
331-490	.6 HP DC Motor 4 Series
331-068	.8 HP DC Motor 5/6 Series
331-168	Electrical Power Cord
331-184	Spacer
331-185	Strain Relief
331-294-99	Sensor
331-297	Potentiometer
331-311	Toggle Switch
331-312	Fuse Holder
331-315-99	Pressure Control Ass'y
331-328	Fuse 20A Slow Blow (5/6 Series)
331-256	Fuse 15A Slow Blow (4 Series)
331-377	LCD - Optional Display

# REPLACEMENT OF ELECTRICAL COMPONENTS

**WARNING** Always unplug the electrical cord before servicing machine.

**NOTE:** Anytime the pressure control assembly, sensor or both are replaced, perform the calibrations.

## PRESSURE CONTROL ASSEMBLY (Electrical Control Board)

1. Unplug machine's power cord.
2. Remove four screws from heatsink housing.
3. Disconnect all leads from pressure control assembly.
4. Reassemble in reverse order.

## SENSOR

1. Remove the 4 screws heat sink and lower the pressure control assembly.
2. Disconnect swivel from sensor by holding sensor with 7/8" wrench and loosening swivel with 11/16" wrench.
3. Disconnect sensor lead from the board. Carefully pull sensor lead out of the terminal box and remove sensor.
4. Reassemble in reverse order.

## POTENTIOMETER

1. Lower pressure control assembly as described above.
2. Disconnect potentiometer lead from pressure control assembly.
3. Use a 1/16" allen wrench, loosen set screw in the potentiometer knob (Fig. 22,) and remove knob and spacer.
4. Using a 1/2" wrench or deep socket, remove the nut from the potentiometer shaft assembly.
5. Pull entire potentiometer assembly out of terminal box.
6. Replace in reverse order.

## LIQUID CRYSTAL DISPLAY (LCD)

1. Lower pressure control assembly as described above.
2. Unscrew the four nuts (6/32") (Fig. 23, Item 5) and remove LCD Display assembly (Fig. 23, Item 6).
3. If unable to loosen the four nuts, hold them and unscrew the four screws (Fig. 23, Item 1). Then remove the LCD Display Assembly. If the display is removed in this manner, the mylar label (Fig. 23, Item 2) must be replaced.
4. Reassemble in reverse order, while making sure that the four spacers (Fig. 23, Item 4) and the four washers (Fig. 23, Item 7) are in place. Tighten the four nuts handtight and seal with blue loctite. DO NOT overtighten the nuts as this will damage the display.

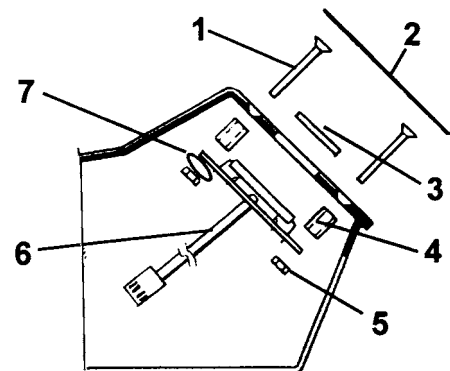
## ON-OFF TOGGLE SWITCH

1. Lower the pressure control assembly as described above.
2. Disconnect the two wires on the switch.
3. Use a 9/16" wrench to loosen the nut on the toggle switch shaft.
4. Reassemble in reverse order.

## FUSE HOLDER

1. Lower pressure control assembly as described above.
2. Disconnect the two wires on the holder.
3. Remove holder cover and fuse.
4. Use 11/16" wrench to remove the nut from the holder shaft.
5. Reassemble in reverse order.

**FIGURE 23**



**PN 331-304 (LCD UPGRADE KIT)**

FIGURE 24 PARTS LIST		
ITEM #	PART #	DESCRIPTION
1	100-362	Screw (4)
2	101-270	Mylar Label - clear
3	331-360	Window
4	117-281	Spacer (4)
5	117-126	Nut (4)
6	331-377	Display Ass'y
7	120-046	Washer (4)

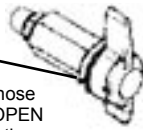
# LP Series Electric Paint Sprayer Quick Reference Guide



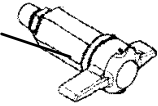
## OPERATION

### Prime Pressure Relief Valve (Prime-PR Valve)

Used to relieve pressure from gun, hose & tip and to prime the unit when in OPEN position. (It is in open position when there is a wider gap between handle and body).



When in the CLOSED position, there is only a very slight gap between handle & body. When the relief valve is closed the system is pressurized. **Handle as a loaded firearm!**



### Pressure Control Knob

Used to adjust pressure only. DOES NOT relieve pressure from gun and system! Turn clockwise to increase pressure, counterclockwise to decrease pressure.



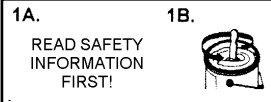
### ON/OFF Toggle Switch

Turns the unit ON and OFF.



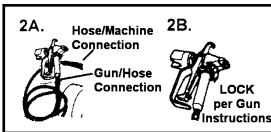
### STEP 1

- 1A. Read safety rules! Read & understand all warnings & safety rules before operating equipment. Know how to lock the gun trigger safety lock before operating the equipment.
- 1B. Stir paint and if necessary strain paint using a paint strainer bag to remove lumps.



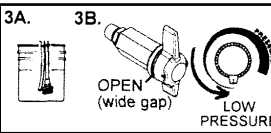
### STEP 2

- 2A. Check gun/hose connections to make sure they are tight.
- 2B. Lock gun trigger safety lock (Airlessco gun shown)  
Note: Plug into 3 pronged grounded electrical outlet. Extension cord must be 3 wire, 12 gauge. Do not coil cord.



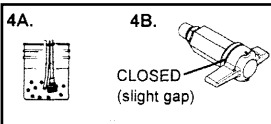
### STEP 3

- 3A. Put pump suction tube into bucket of paint.
- 3B. Turn the Prime-Pressure Relief Valve to open position (wide gap between handle & body).  
Turn toggle switch ON, and adjust to low pressure on the pressure control knob. The unit will now self-prime.



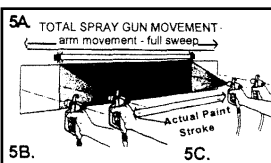
### STEP 4

- 4A. Wait about one minute until fluid comes out of the return tube (smaller diameter tube).
- 4B. Turn the Prime-Pressure Relief Valve to closed position. (slight gap between handle and body)  
**CAUTION: THE UNIT IS NOW PRESSURIZED!**



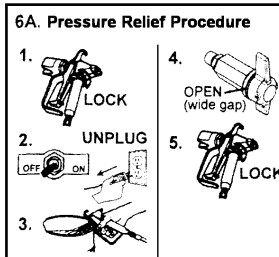
### STEP 5

- Note:** Leave the Prime-Pressure Relief Valve fully closed and very carefully unlock the guns trigger safety lock.
- 5A. Aim the gun 12" from test surface (cardboard) and spray out the storage solution. Turn the pressure control knob clockwise to increase pressure. Increase the pressure enough to atomize the paint & give a full pattern. Use the lowest pressure possible.
  - 5B. Always keep the gun perpendicular to the surface. Move the gun at a steady rate. It is important to "trigger" the gun after gun movement has begun and release trigger before gun movement ends.
  - 5C. Overlap half the width of each paint stroke.



### STEP 6

- 6A. Release pressure when you stop spraying & before servicing gun or machine or before changing or cleaning gun tip by:
  1. Lock the gun trigger safety.
  2. Turn toggle switch to OFF position and unplug from electrical outlet.
  3. Release gun safety lock and trigger gun to relieve residual pressure.
  4. Turn Prime/PR Valve to open position.
  5. Relock gun safety latch.
- 6B. Submerge gun in water (if using latex) or thinner (oil-base) to prevent paint from drying in the gun nozzle.



## CLEANING

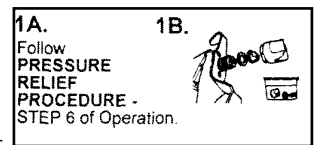
- Always use low pressure in the cleaning process.
- Always remove spray tip before cleaning—**AFTER following the Pressure Relief Procedure!**
- Use a metal bucket for cleaning and maintain firm metal to metal contact of gun to the bucket.

### TOOLS & EQUIPMENT NEEDED:

1. Soft bristle brush, clean-up rags.
2. 8" crescent wrench for removing gun tip & filter in gun handle.
3. Prepared 5 gal. bucket of soapy water if using latex, or mineral spirits if using oil-based. (Second bucket will usually be required).
4. Empty bucket for wastes.
5. Storage solution of Pump Conditioner mixed with 1 gal. of water if using latex OR compatible paint thinner if using oil-based paint.

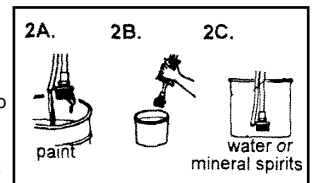
### STEP 1

- 1A. **IMPORTANT: Relieve pressure by following the Pressure Relief Procedure, Step 6 of Operation, and be sure gun safety lock (latch) is in locked position.**
- 1B. Remove tip and tip guard from spray gun and place in mineral spirits or water.



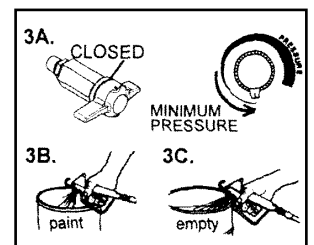
### STEP 2

- Note:** Turn unit ON. Turn pressure control knob to low pressure.
- 2A. Lift suction tube and return tube out of paint and hold over paint bucket. Any paint remaining in the unit will return into the bucket out through the return tube.
  - 2B. Wipe excess paint from suction tube.
  - 2C. Place suction tube into prepared bucket of water or mineral spirits.



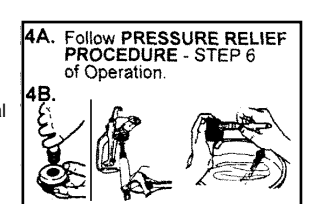
### STEP 3

- Note:** Release the gun trigger lock very carefully.
- 3A. Turn the Prime/PR Valve to the closed position. Adjust the pressure control knob for minimum pressure. **IMPORTANT: Never use high pressure for cleaning!**
  - 3B. Trigger gun into paint bucket to allow paint to run out of hose and gun.
  - 3C. Place gun over empty metal bucket and trigger gun using VERY LOW PRESSURE & maintaining firm metal to metal contact for 3-4 minutes until it runs clean. (Second bucket may be required).



### STEP 4

- 4A. **IMPORTANT: Follow Pressure Relief Procedure Step 6A of Operation!**
- 4B. Remove filters from suction tube and gun handle. Clean with water or mineral spirits and soft brush and reassemble suction and gun filter only. **DO NOT** reassemble gun tip and tip guard at this point.



### STEP 5

- 5A. Mix bottle of Pump Conditioner with 1 gal. of water or prepared mineral spirits and put suction tube into pail. Prime unit (Prime/PR Valve Open Position & Pressure Control Knob in low position) Trigger gun to fill the hose & gun. LEAVE this mixture in the pump & hose for storage. **DO NOT DISCHARGE.** Turn motor off while the suction tube remains in the bucket.
- 5B. Disconnect from power.
- 5C. Roll up hose and tape. Now reassemble gun with spray tip and tip guard. After you have disconnected sprayer from electrical power, turn Prime/PR Valve to the closed position for storage.

